

IMPLICIT STATISTICAL LEARNING IN FAST PERIODIC VISUAL STIMULATION

Mara De Rosa¹, Maria Ktori¹, Yamil Vidal¹, Roberto Bottini² & Davide Crepaldi¹

¹International School for Advanced Studies (SISSA), Trieste, Italy

²Center for Mind/Brain Sciences (CIMEC), University of Trento, Trento, Italy

SNL 2020 Annual Meeting



FAST PERIODIC VISUAL STIMULATION

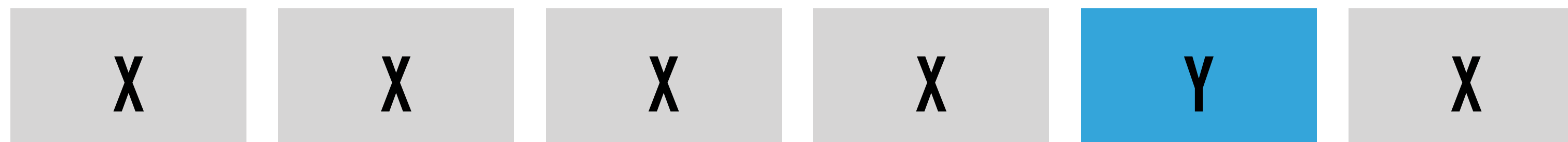
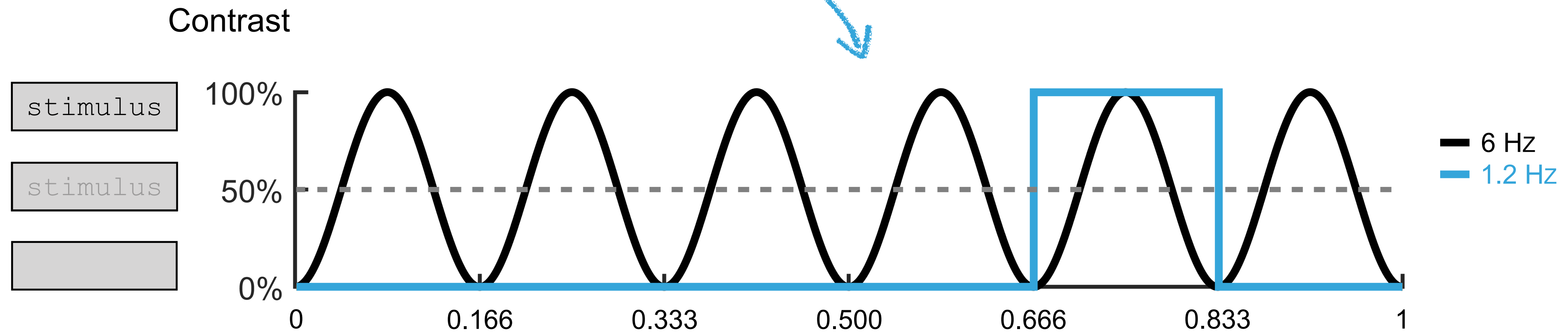

ODDBALL PARADIGM

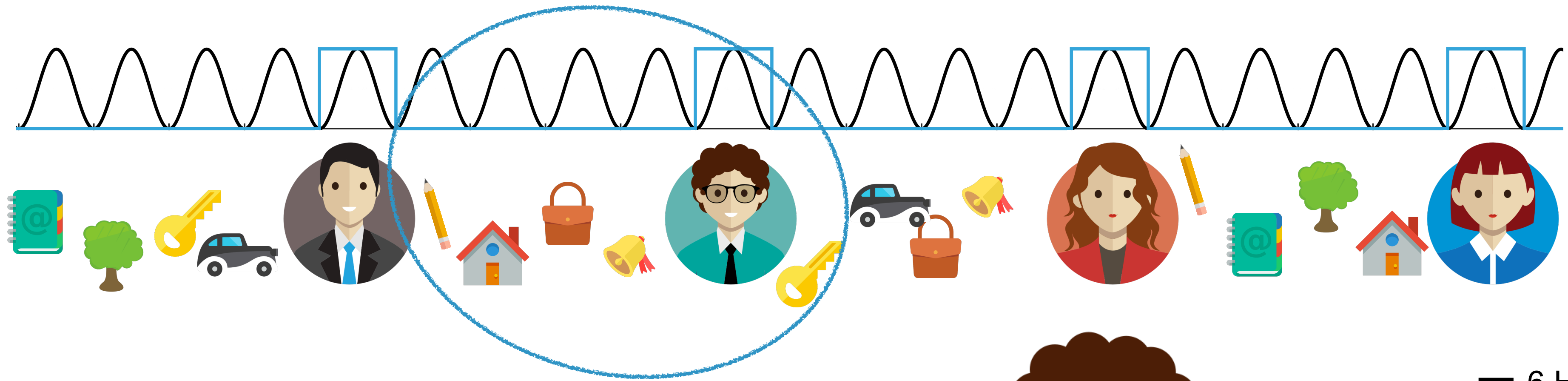

— 6 Hz
— 1.2 Hz

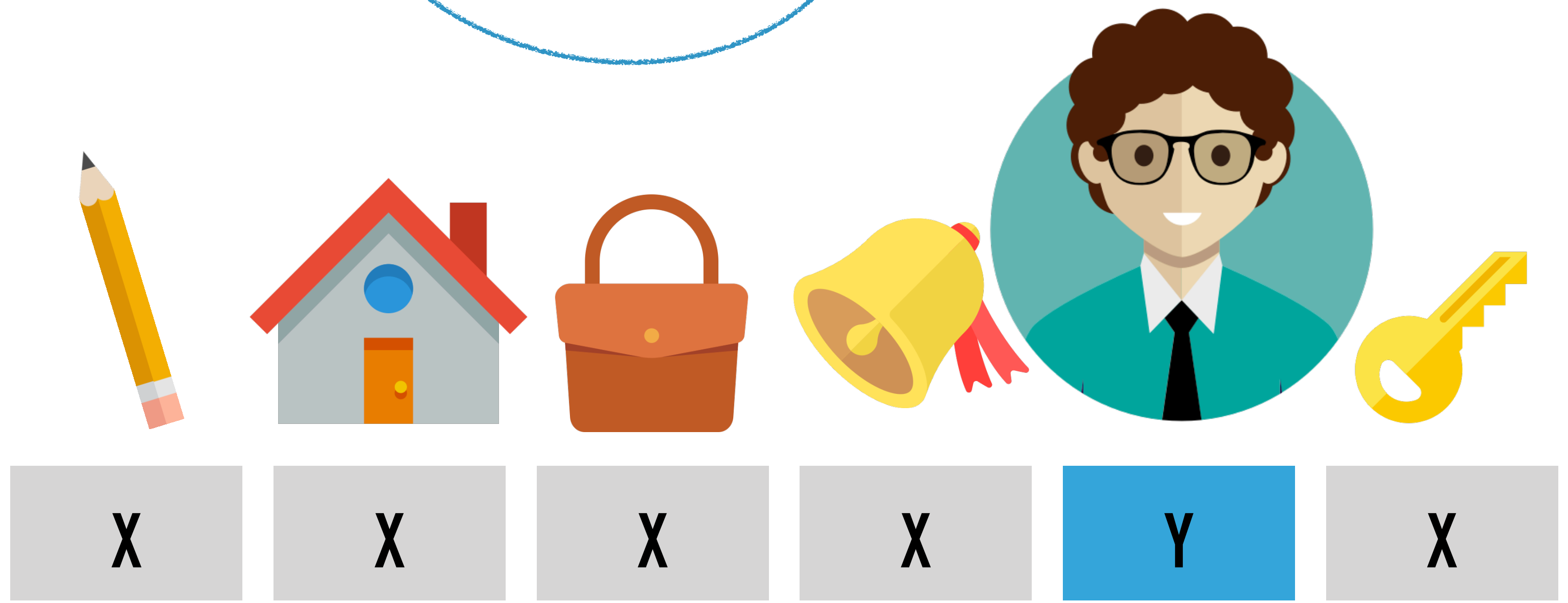

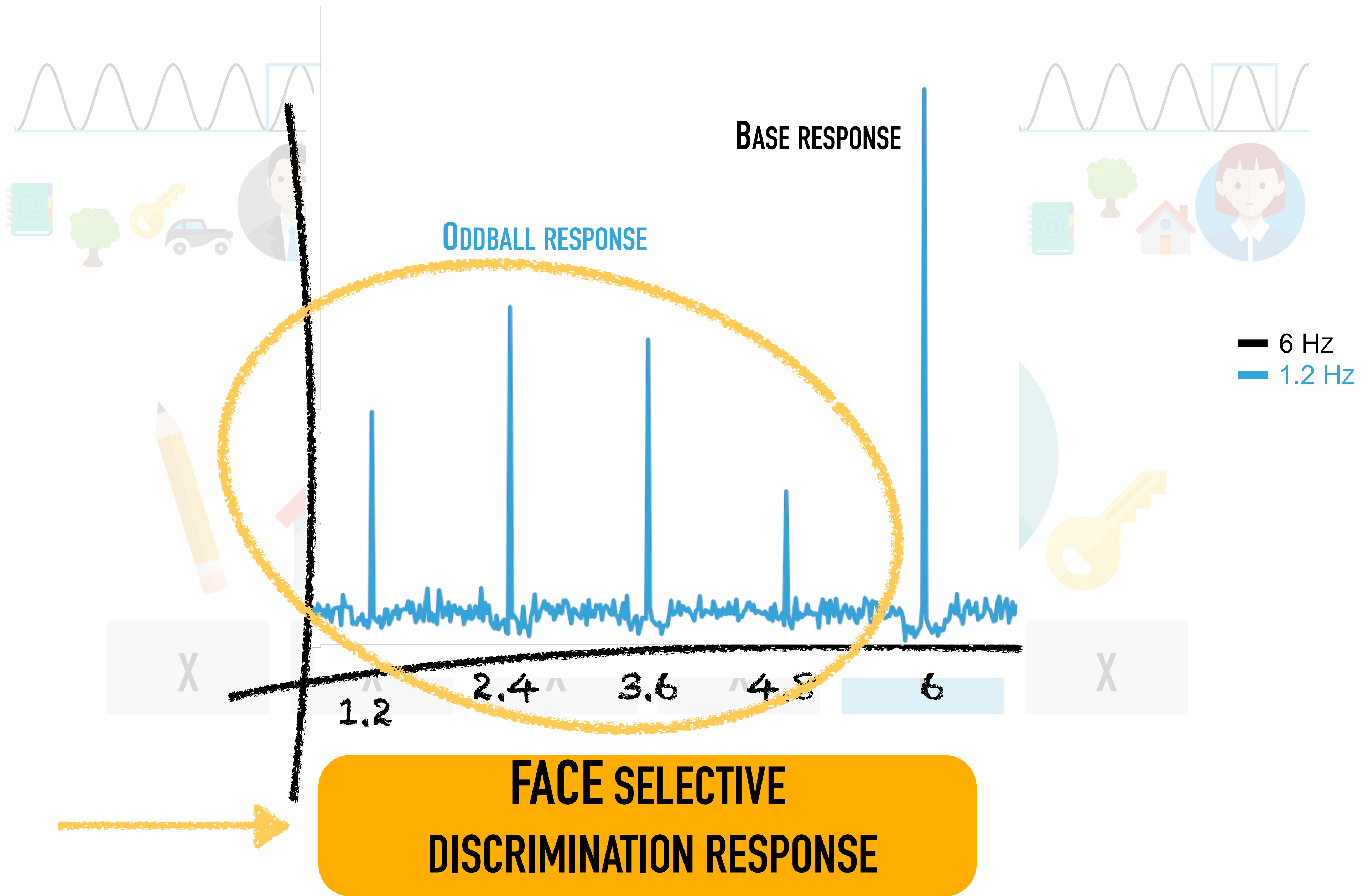

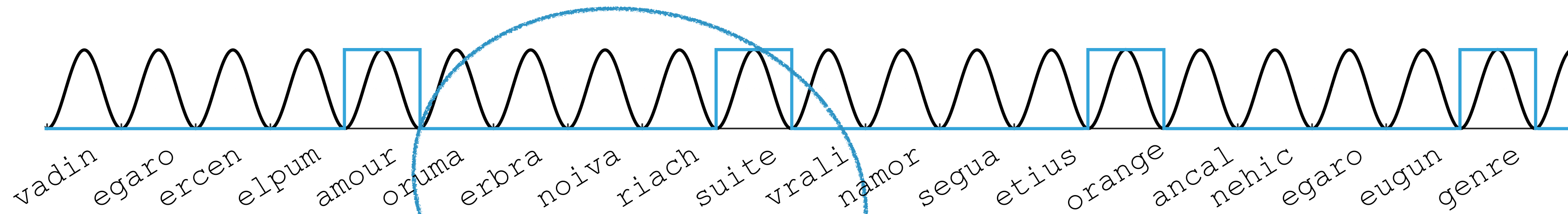

oruma
erbra
noiva
riach
suite
vrali

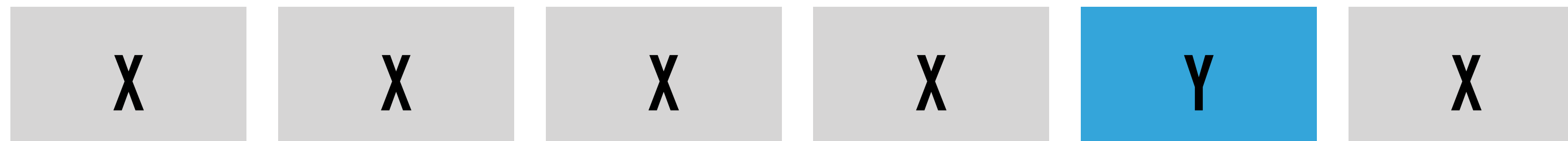

→ **WORD SELECTIVE
DISCRIMINATION RESPONSE**

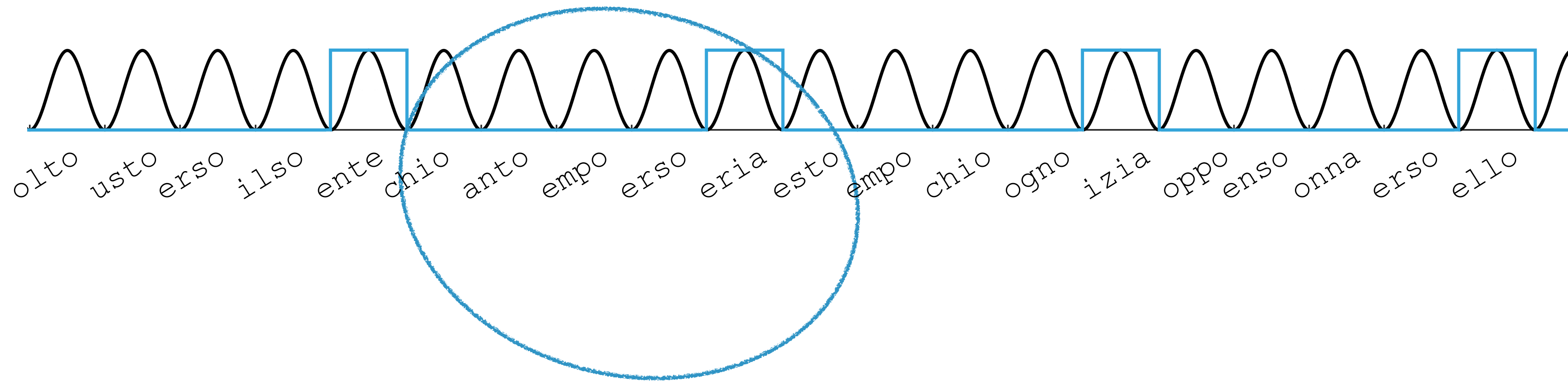

chio anto empo erso eria esto

X X X X Y X

→ MORPHEME SELECTIVE DISCRIMINATION RESPONSE

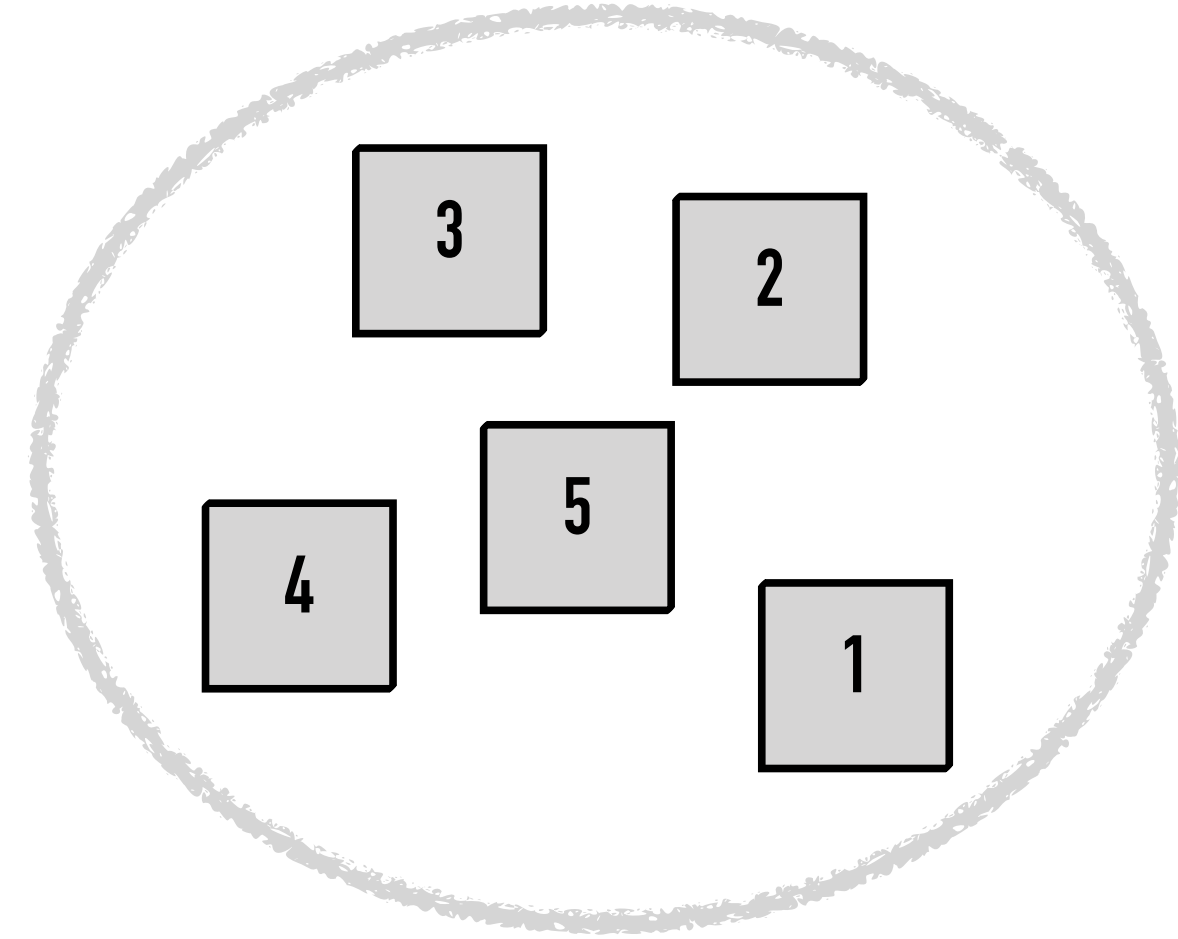
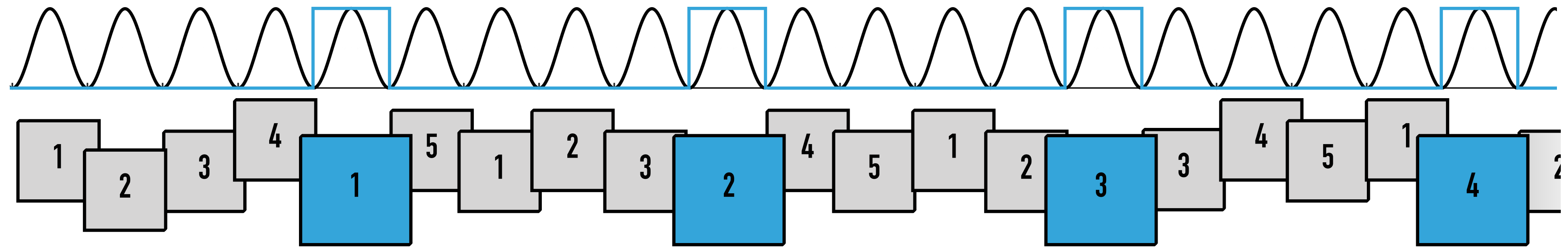

X 4

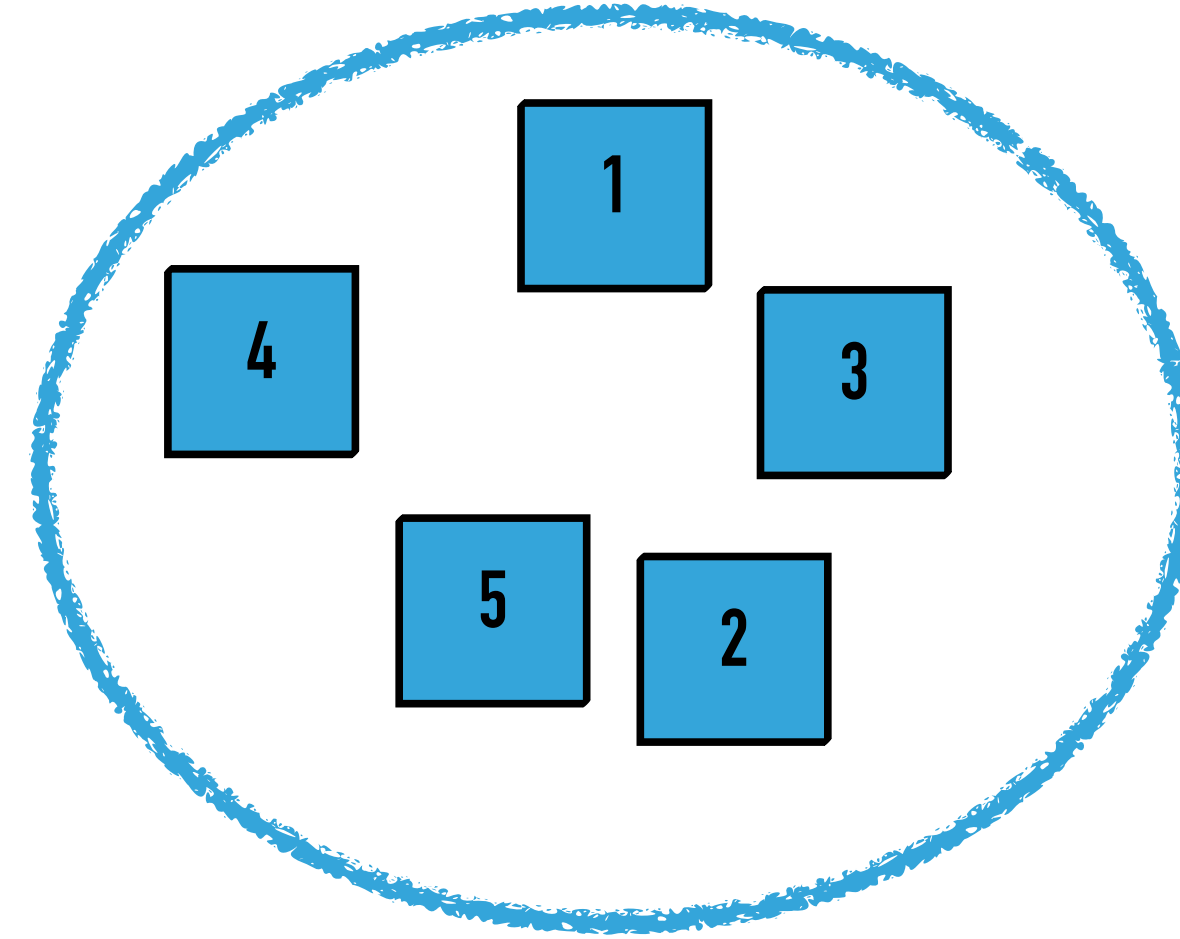

X 1



**CAN
CATEGORY-
SELECTIVE
RESPONSES BE GENERATED BY
IMPLICIT STATISTICAL
LEARNING?**

**DOES
STIMULUS FAMILIARITY
MODULATE SUCH RESPONSE?**

THE "X IN X" LOGIC

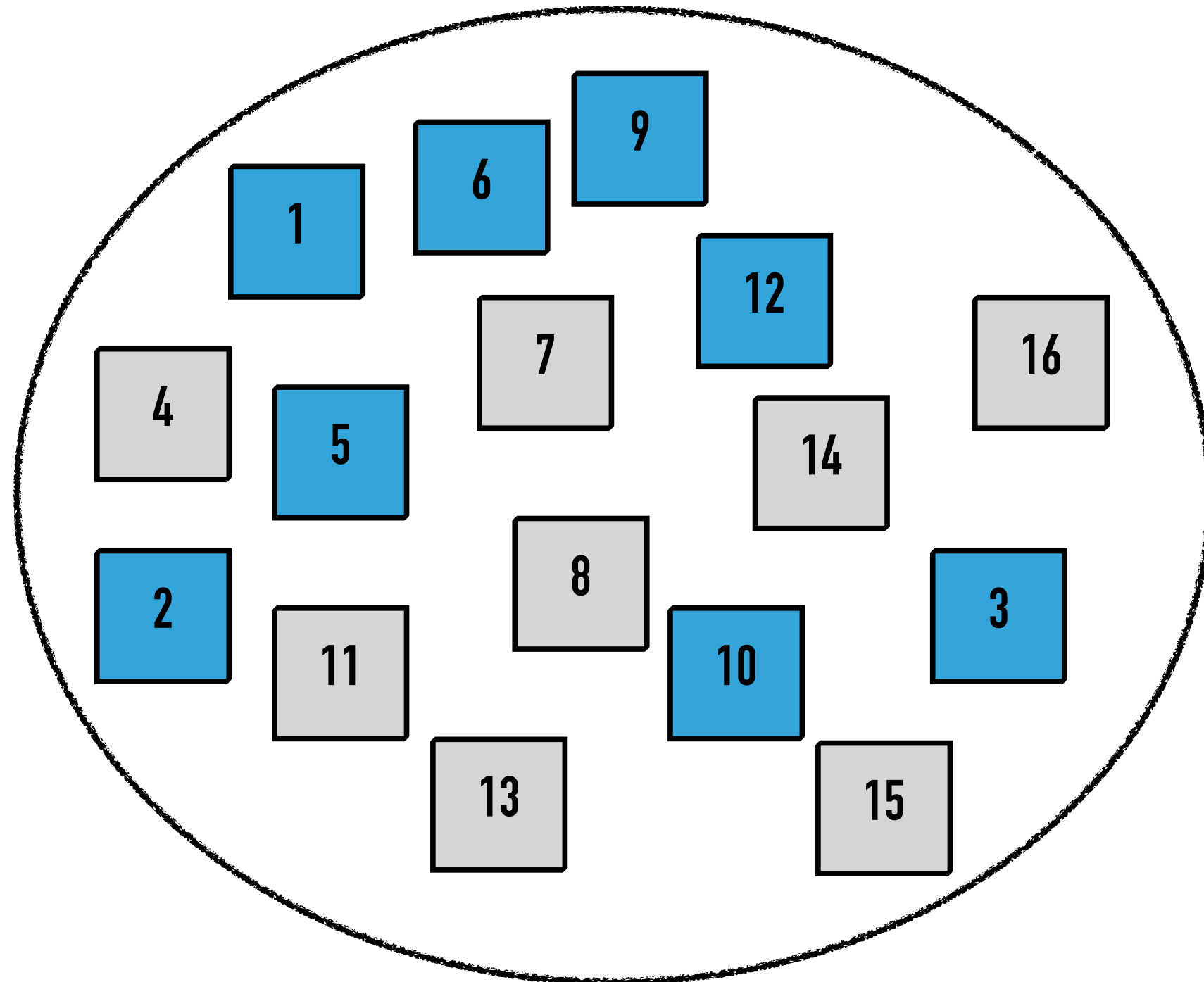
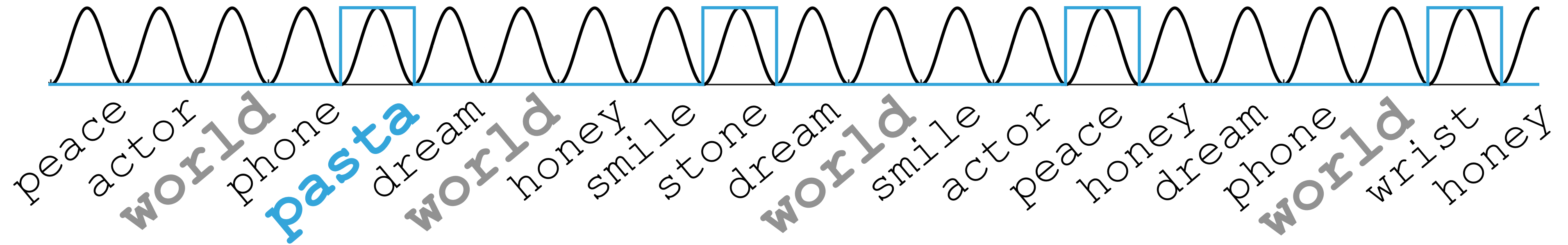

8 ITEMS

X 36 TIMES

8 ITEMS

X 9 TIMES

WORDS in WORDS

crema salto mosca ombra **pasta** dieta

PSEUDOWORDS in PSEUDOWORDS

macre tolsa scamo broma **stapa** tadie

NONWORDS in NONWORDS

dfgbr lmngp rtmnv qsg hv **prnzl** tvlsr

PSEUDOFONTS in PSEUDOFONTS [Vidal & Chetail, 2015]

ƒcθ>σ σ∫τϕϑ ƒδRΛc Dωθ∫R **πτϕσϑ** Dωθ∫R

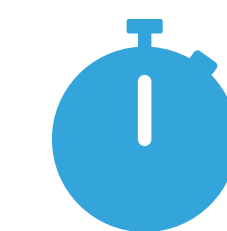

5 x 4 x 60" sequences

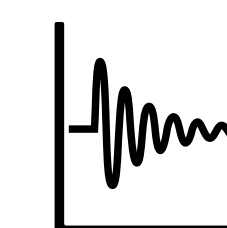

Base:
6 Hz



Oddball:
1.2 Hz



30 subjects

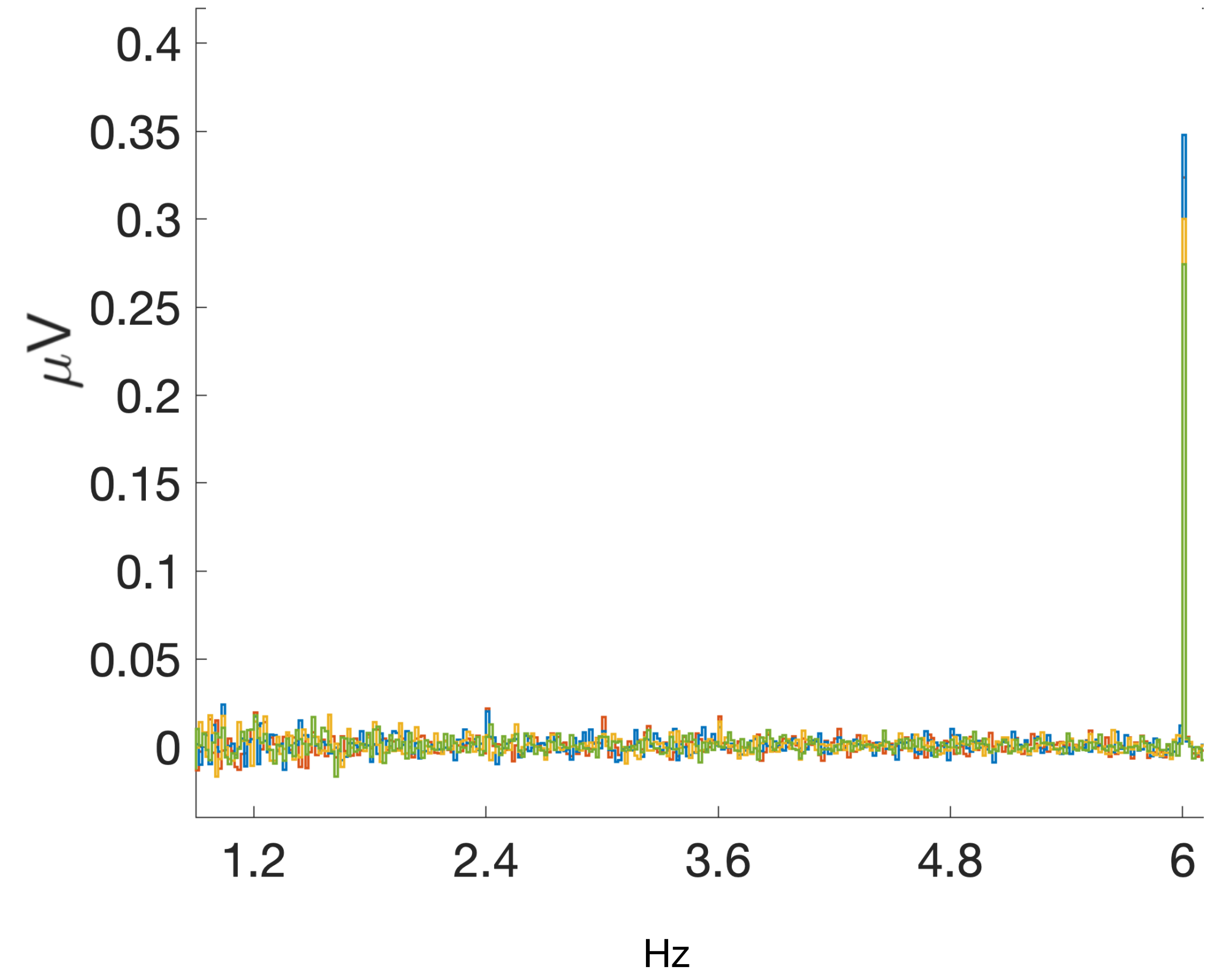
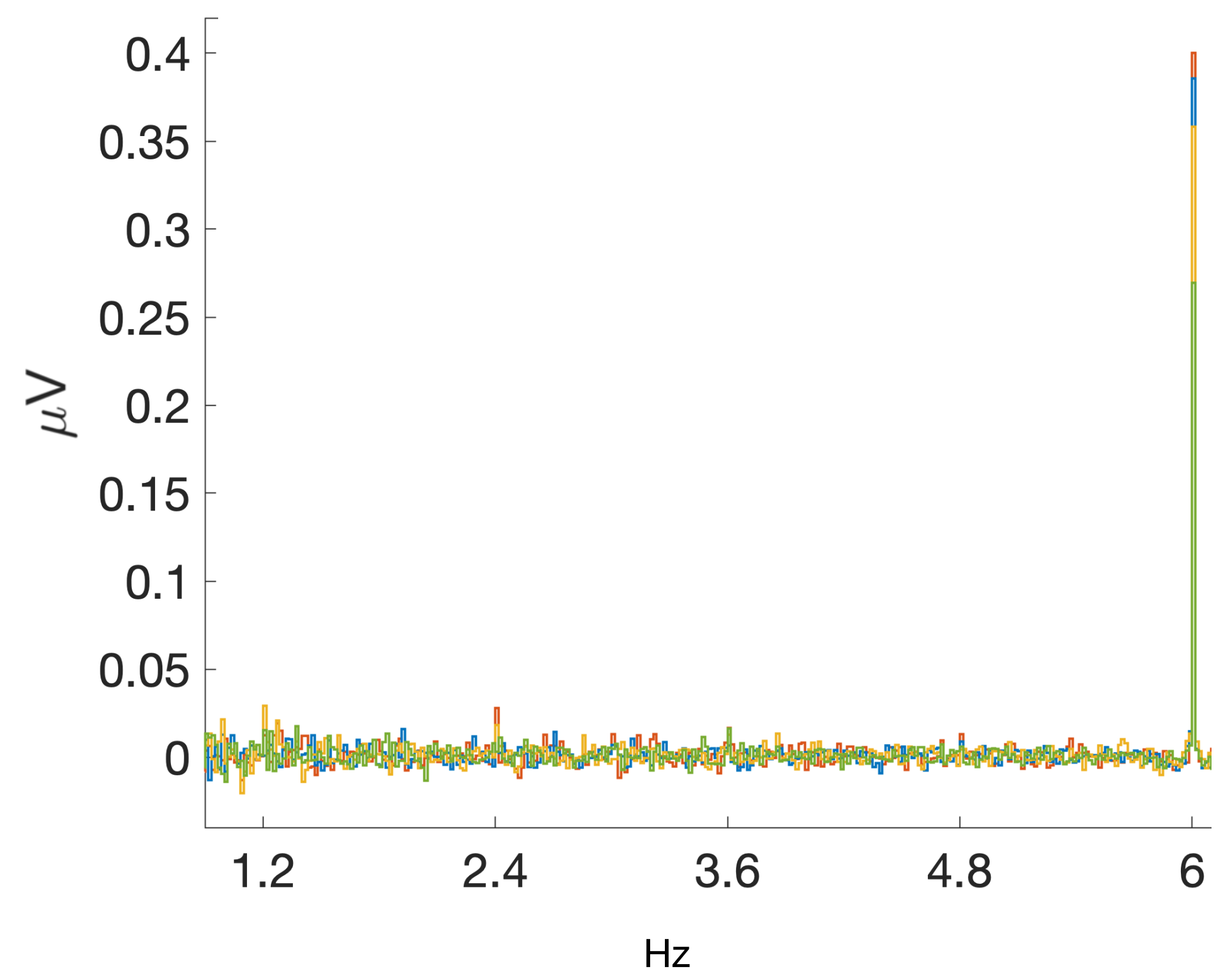
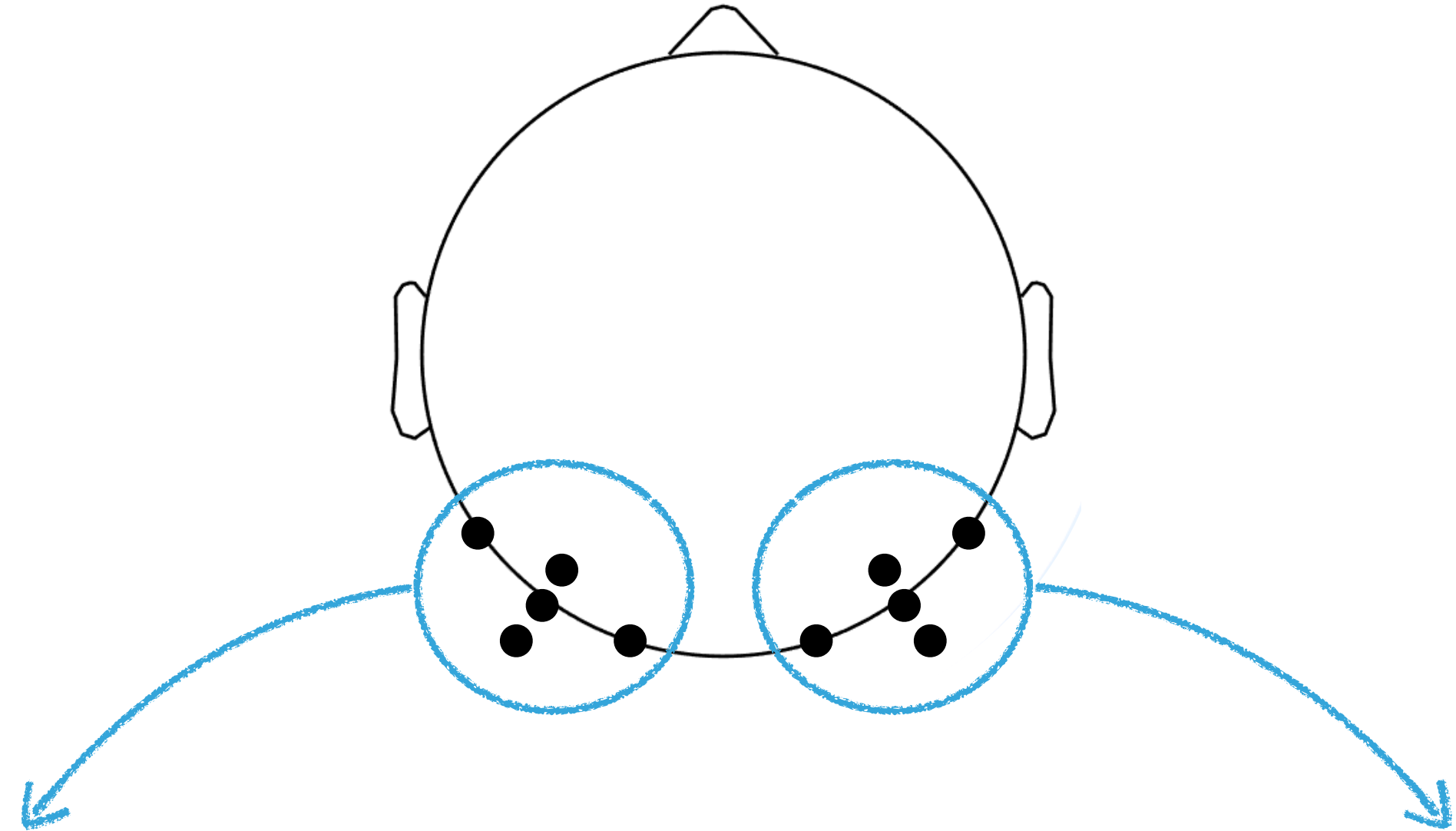

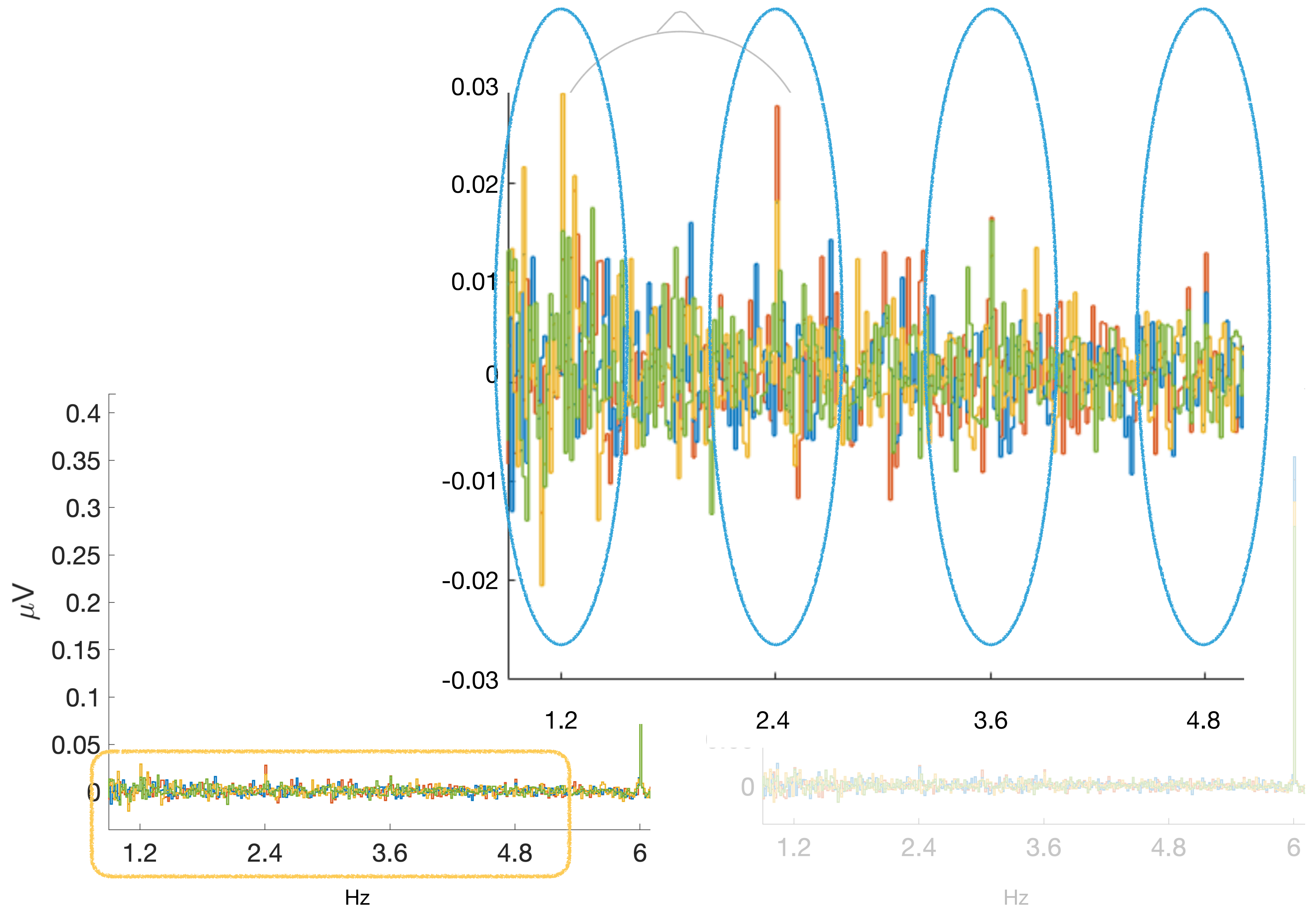

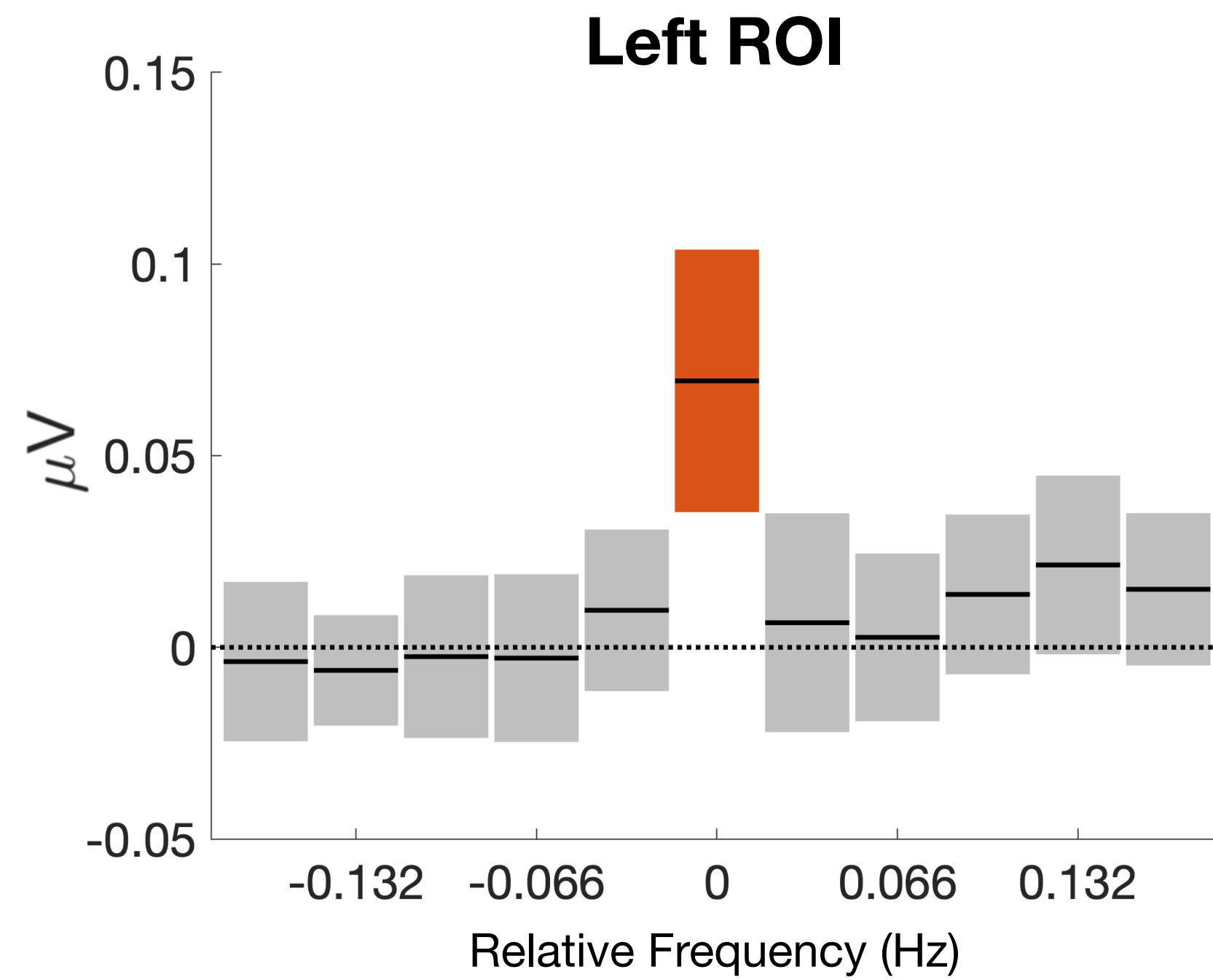
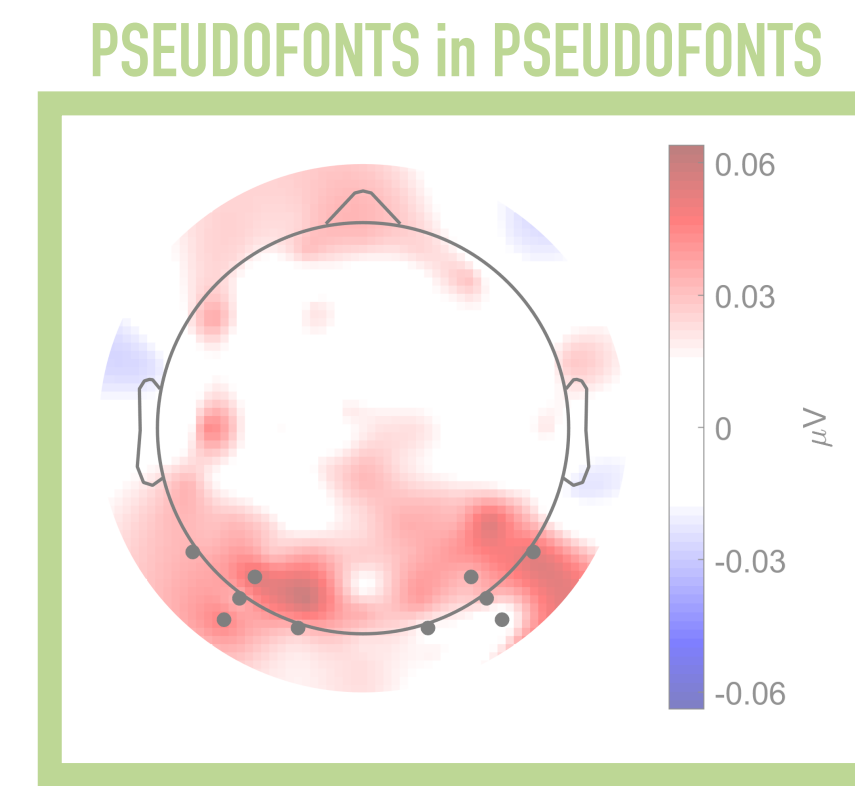
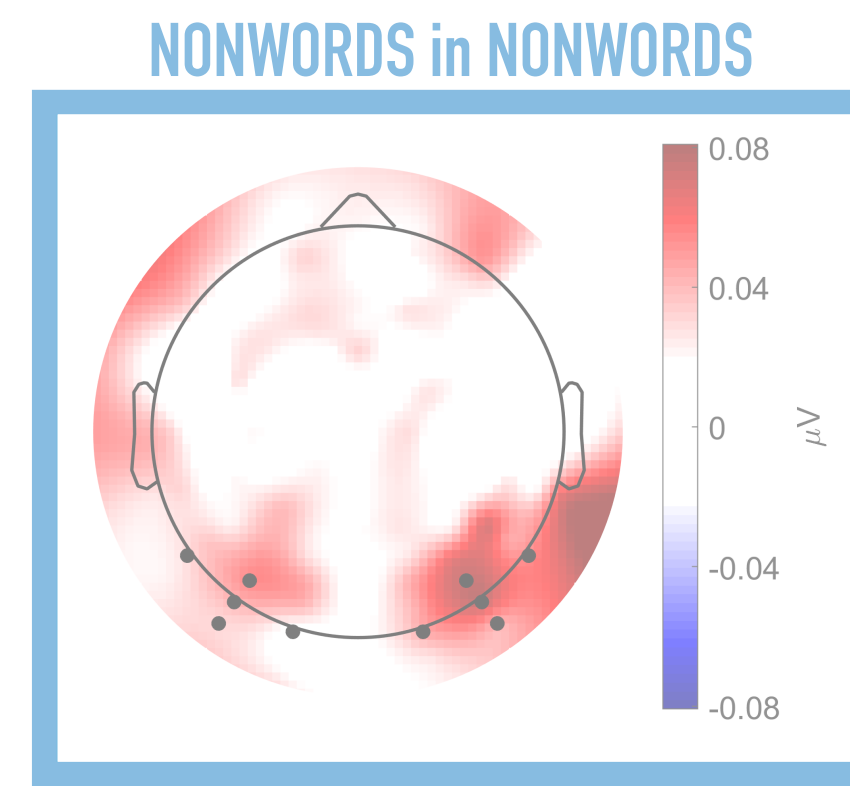
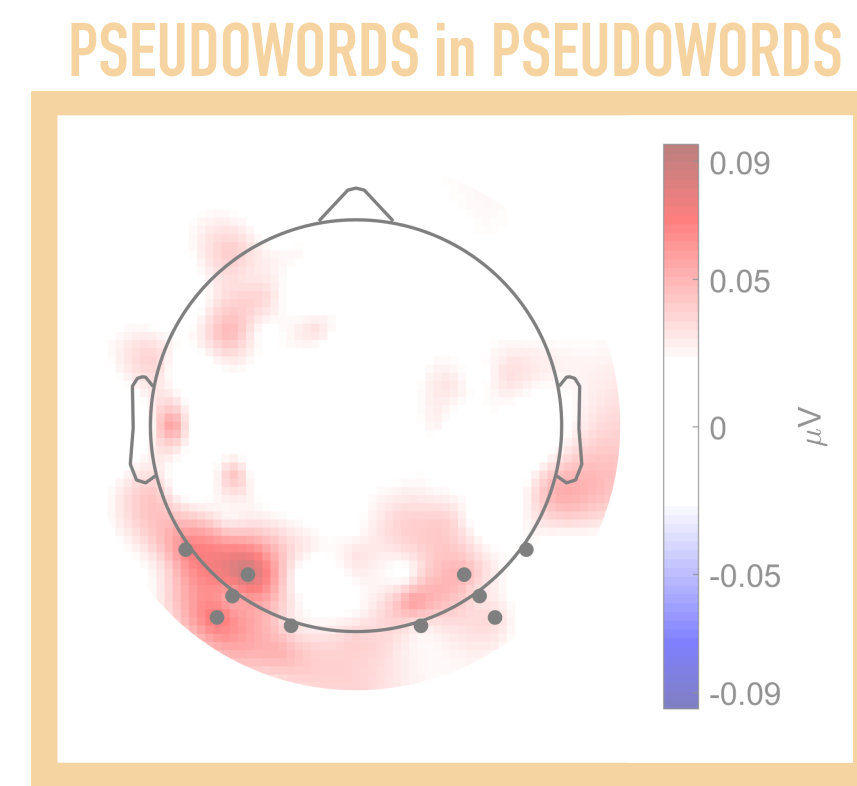
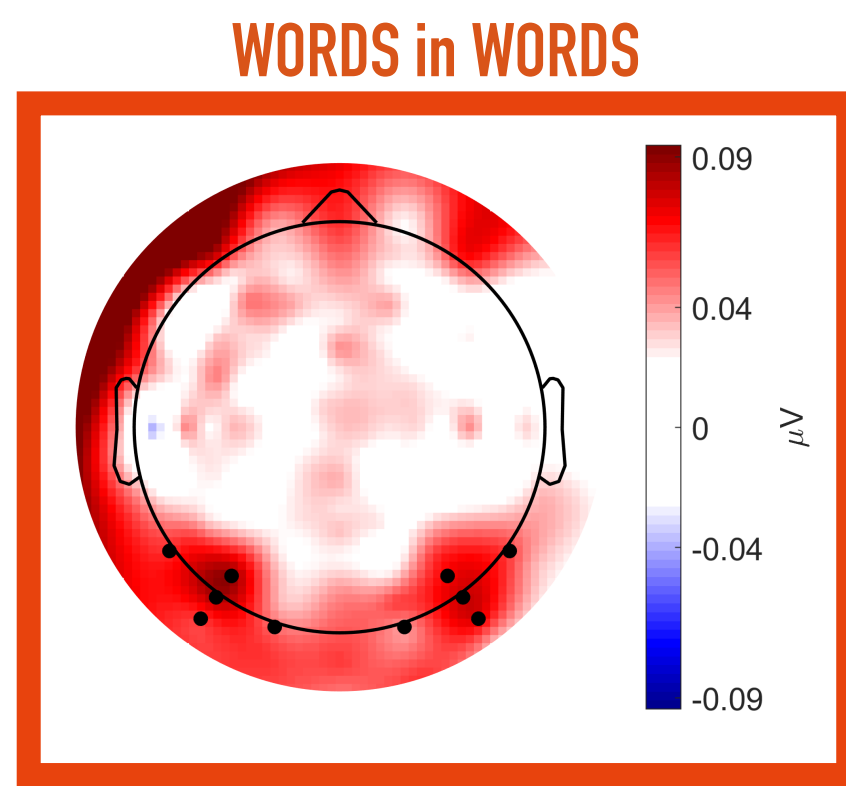

$t = 4.16, g=0.77 [0.35, 1.18] p=0.0003$

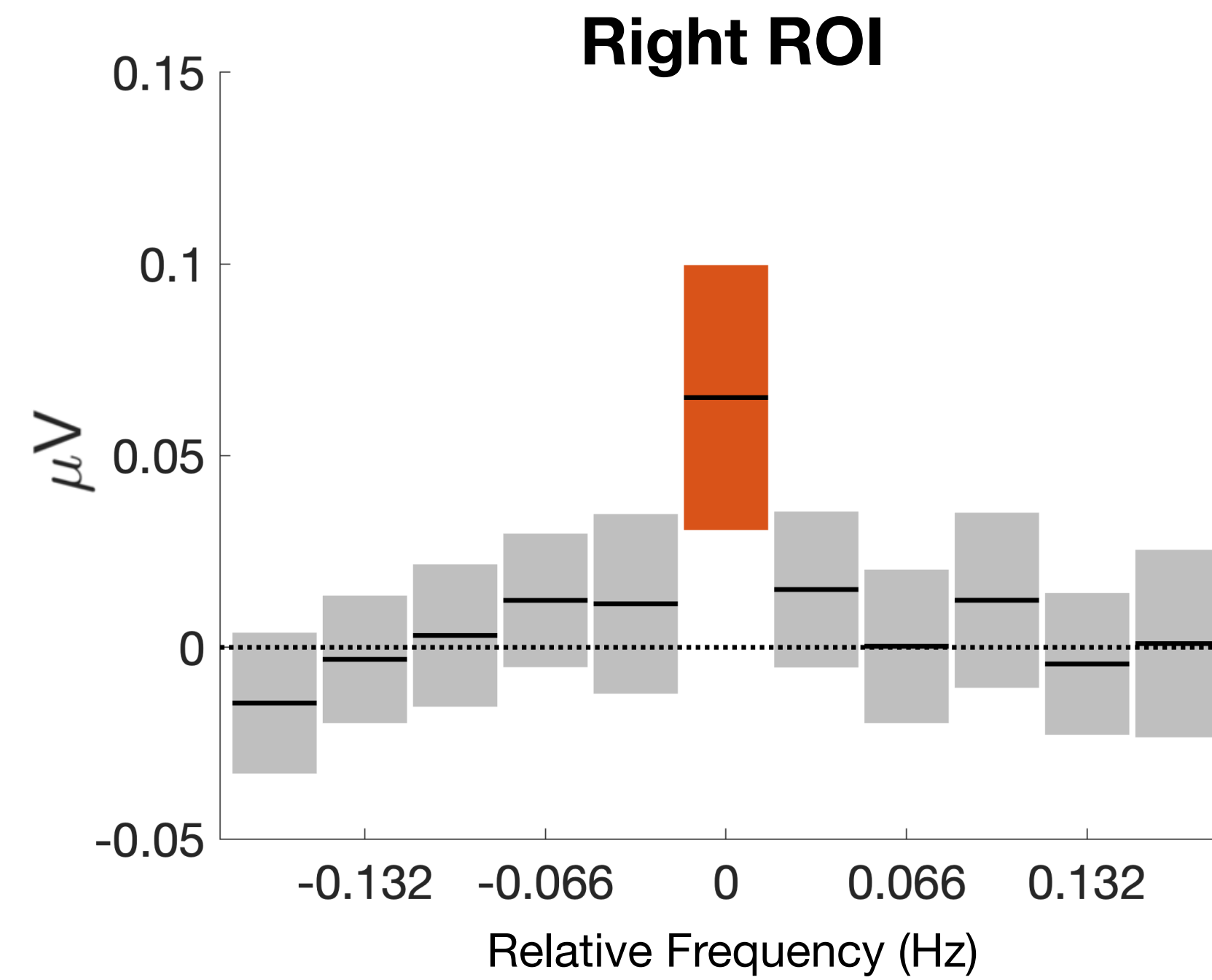

$t = 3.87, g=0.72 [0.30, 1.12] p=0.0006$

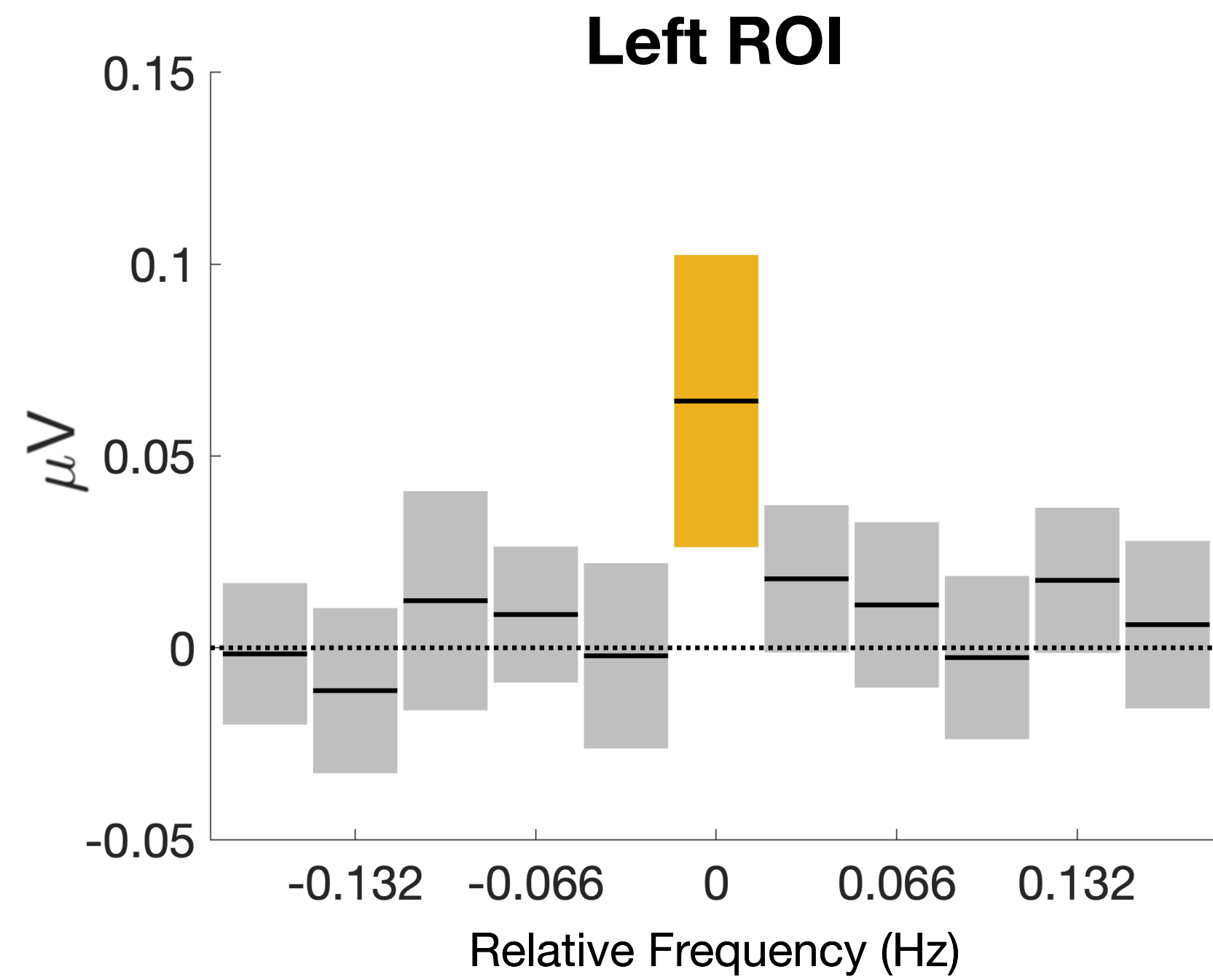
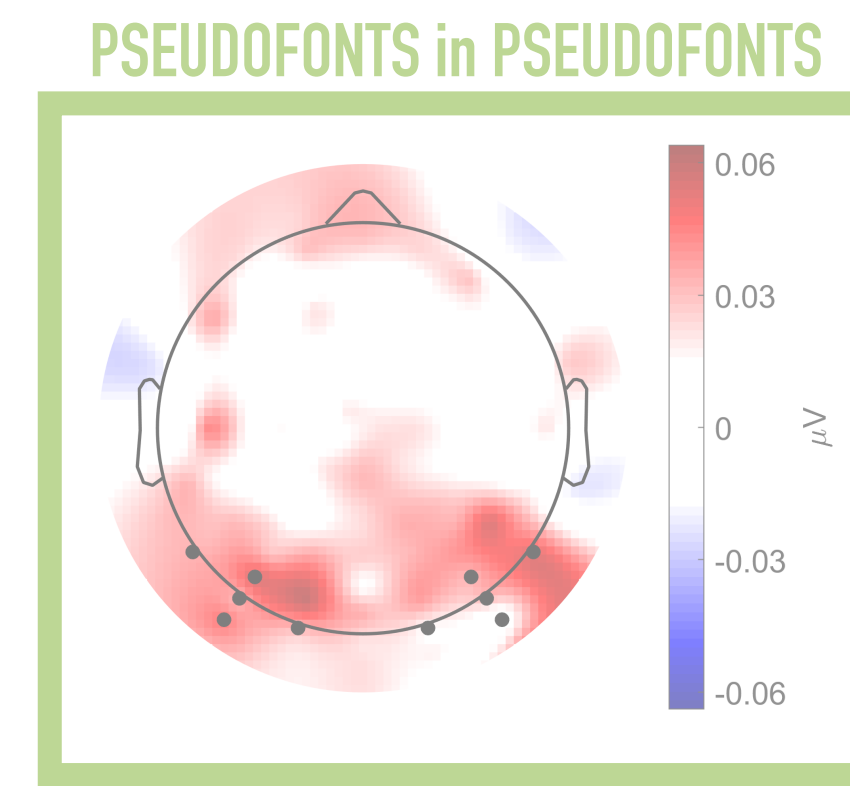
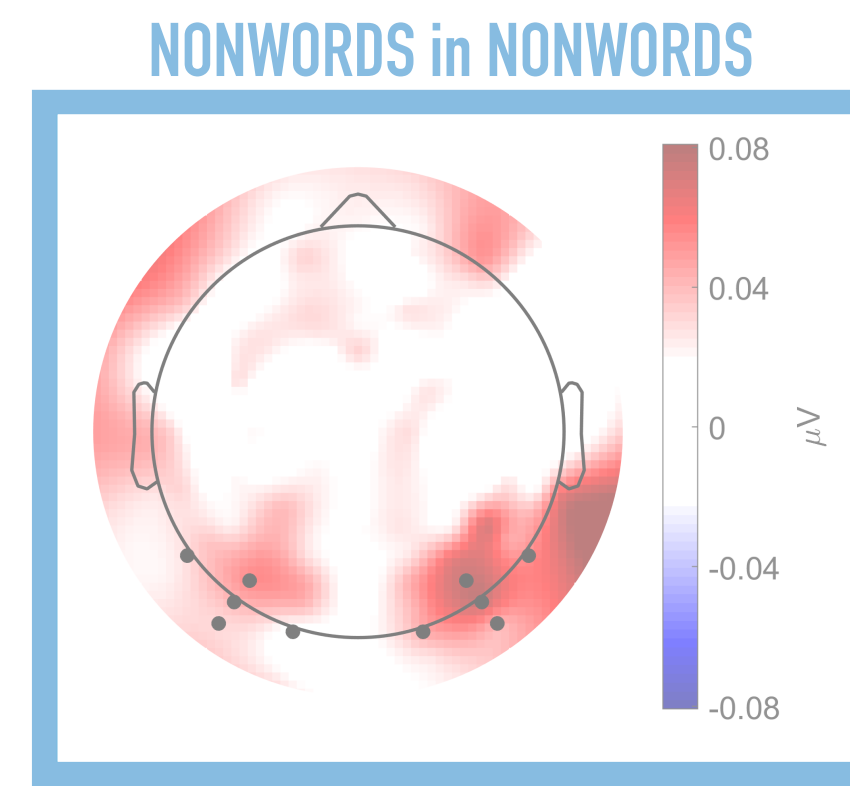
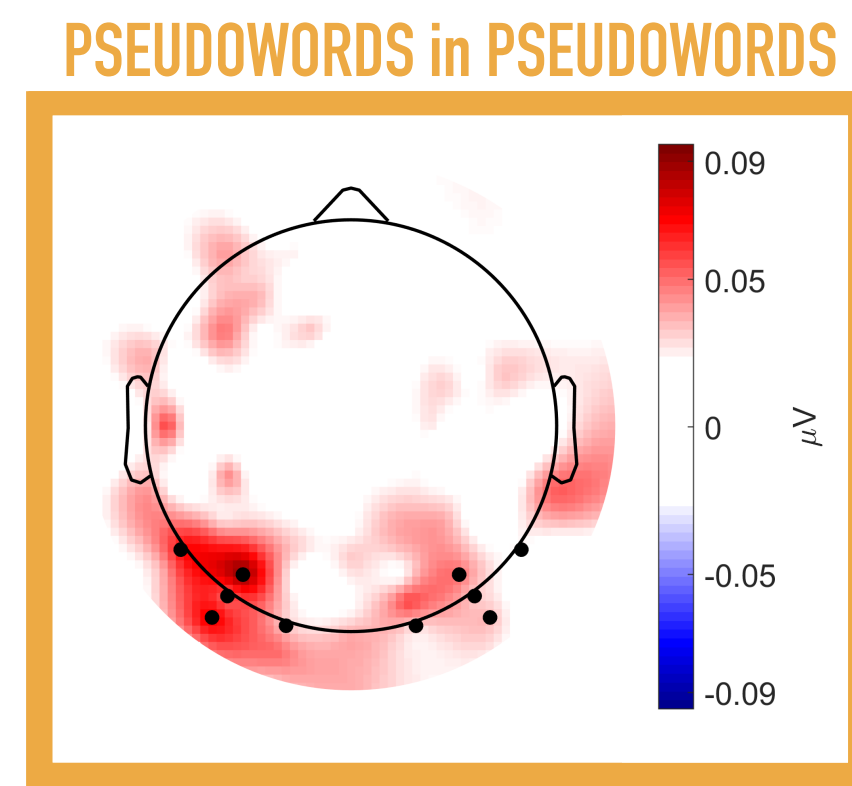
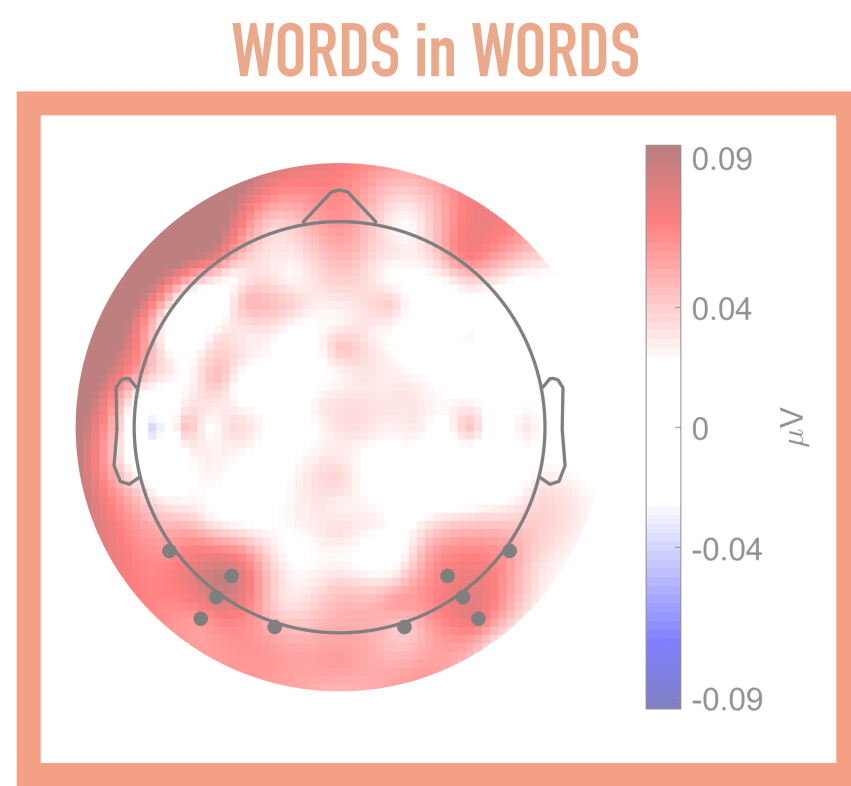

$t = 3.46, g=0.64 [0.28, 1.04] p=0.0017$

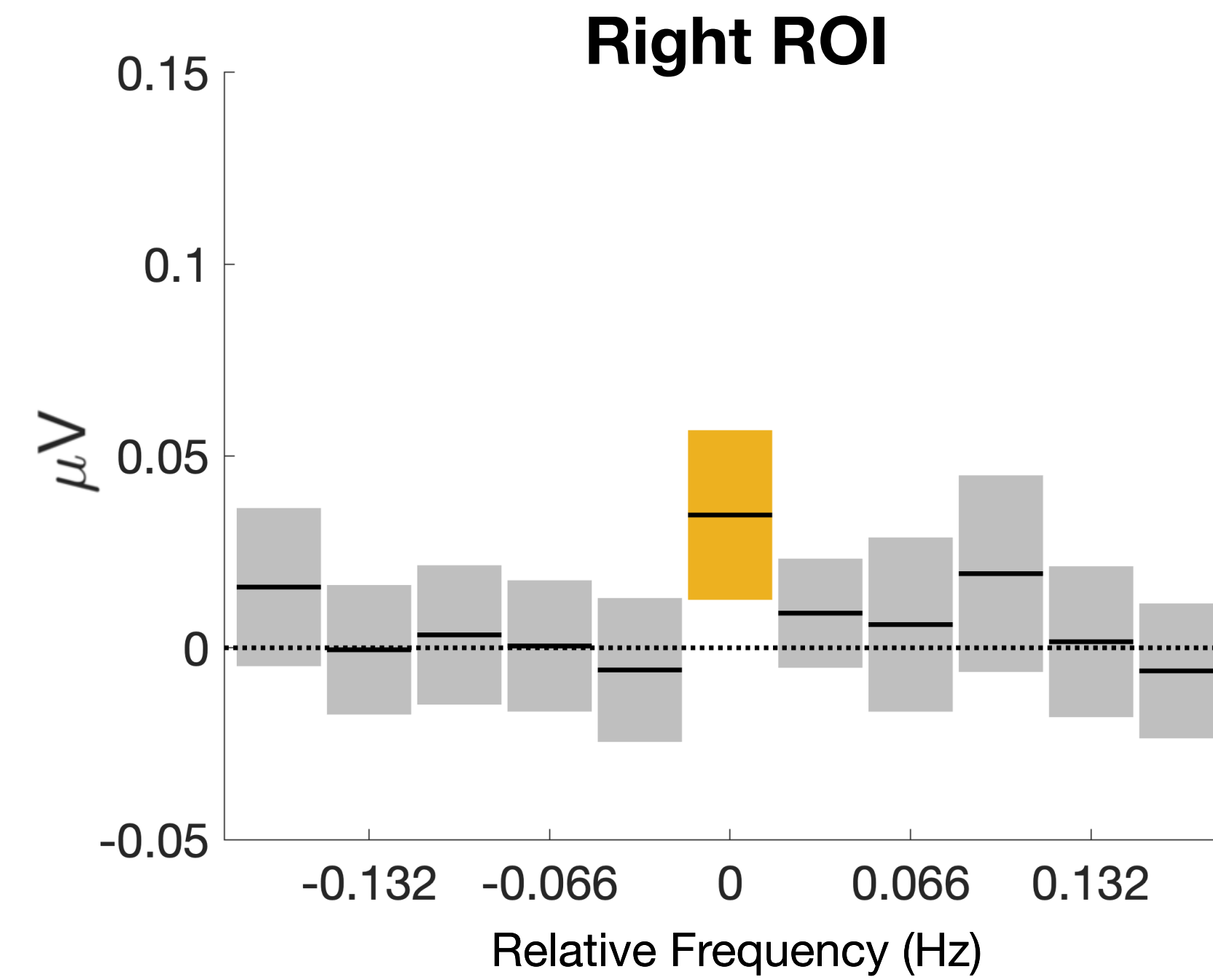

$t = 3.20, g=0.59 [0.19, 0.99] p=0.0033$

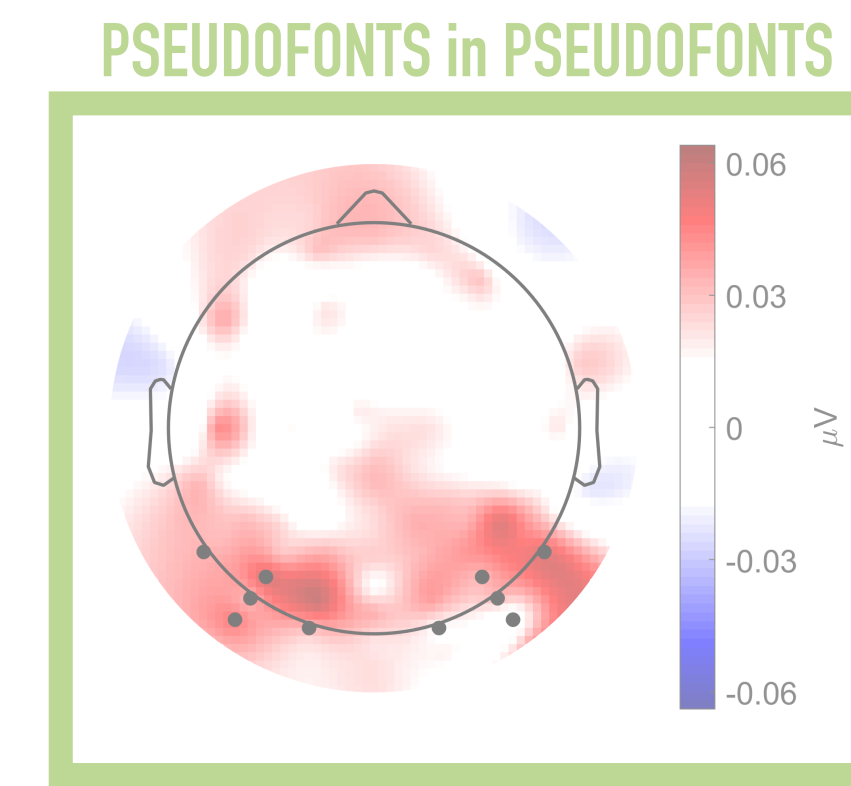
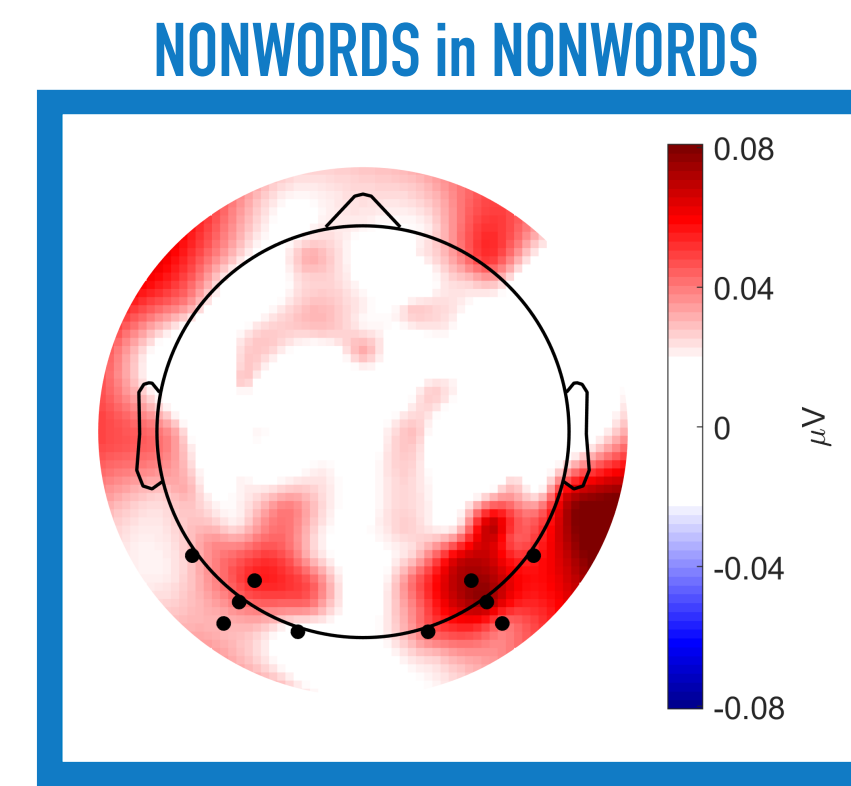
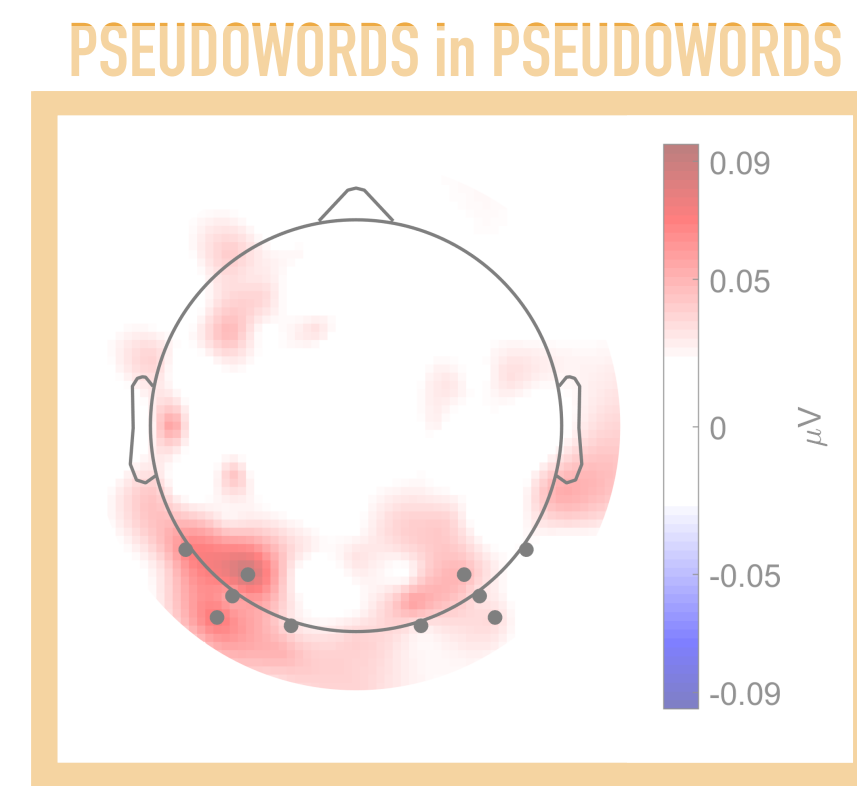
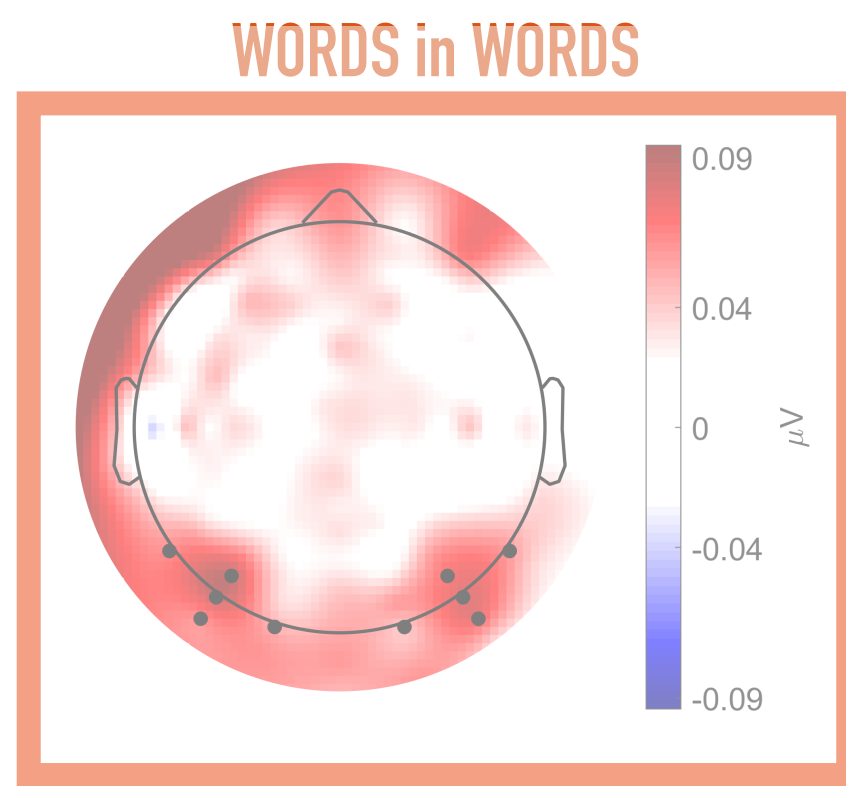

Left ROI

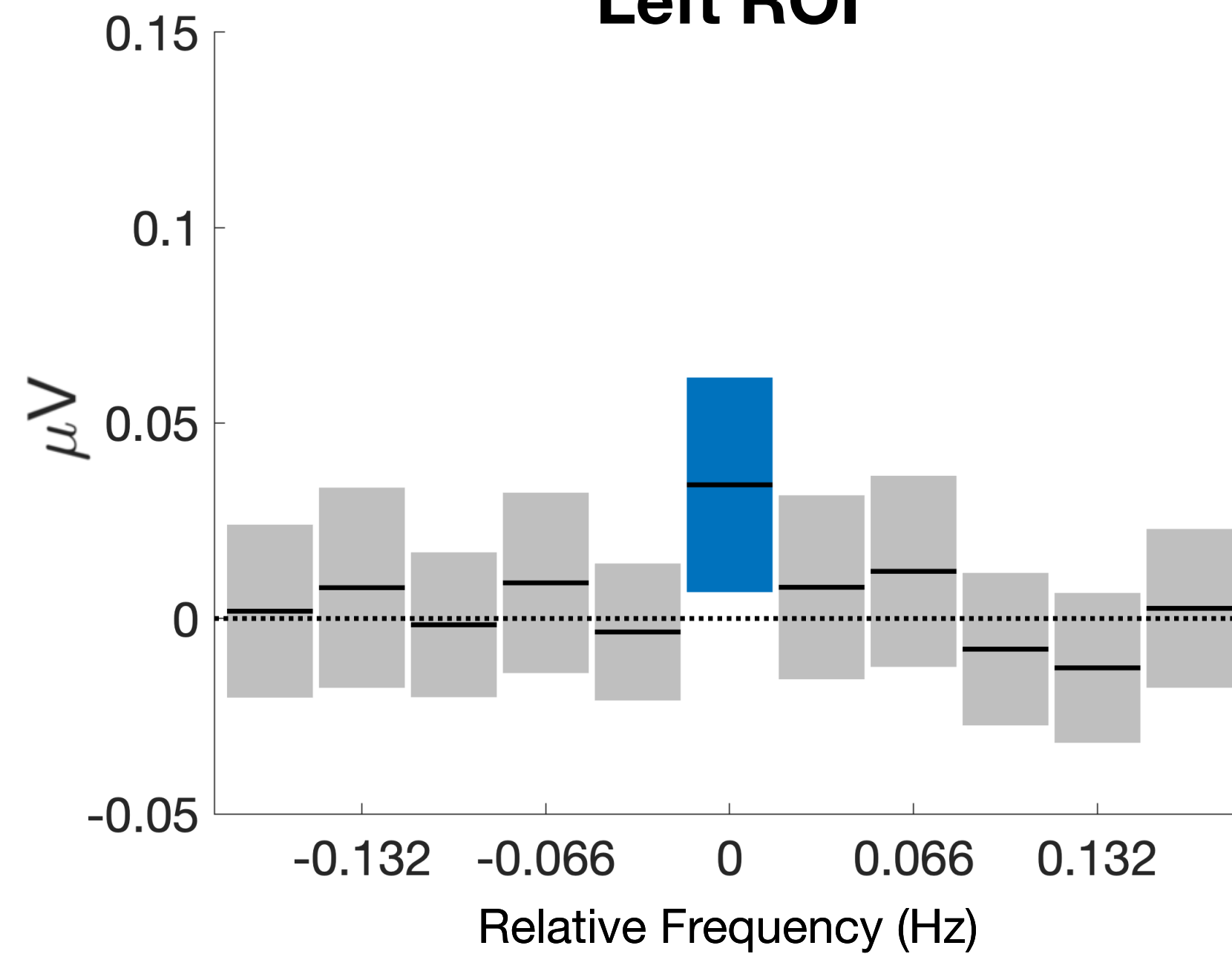

$t = 2.55, g=0.47 [0.08, 0.85] p=0.0164$

Right ROI

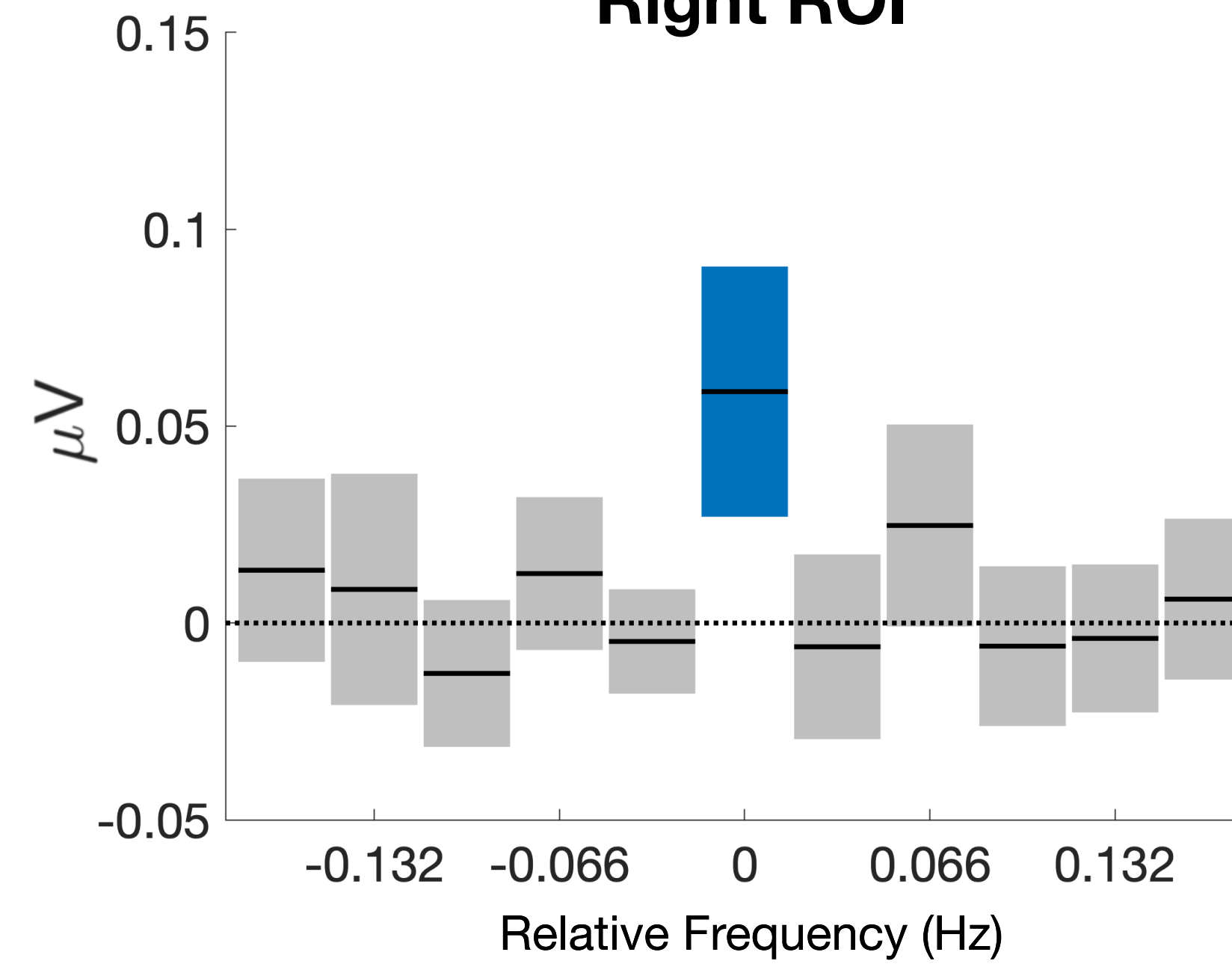

$t = 3.79, g=0.70 [0.29, 1.10] p=0.0007$

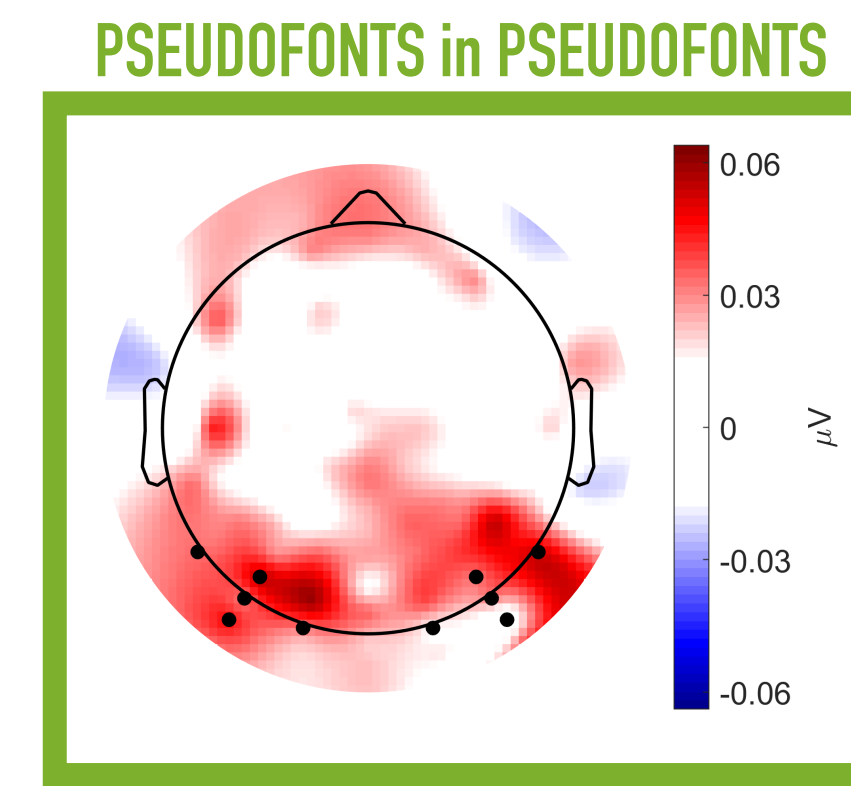
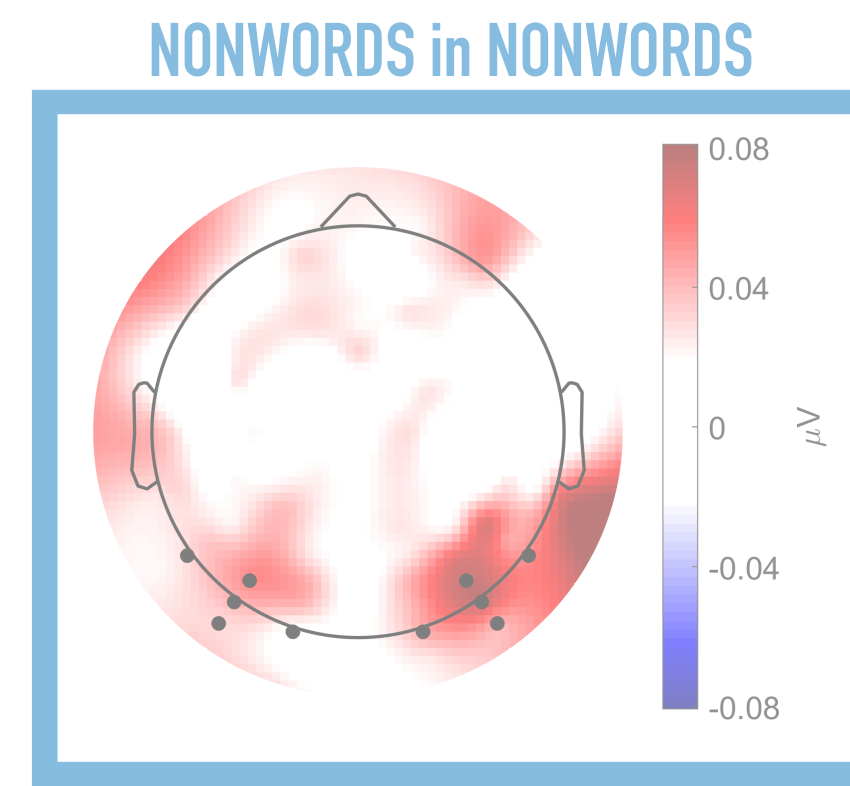
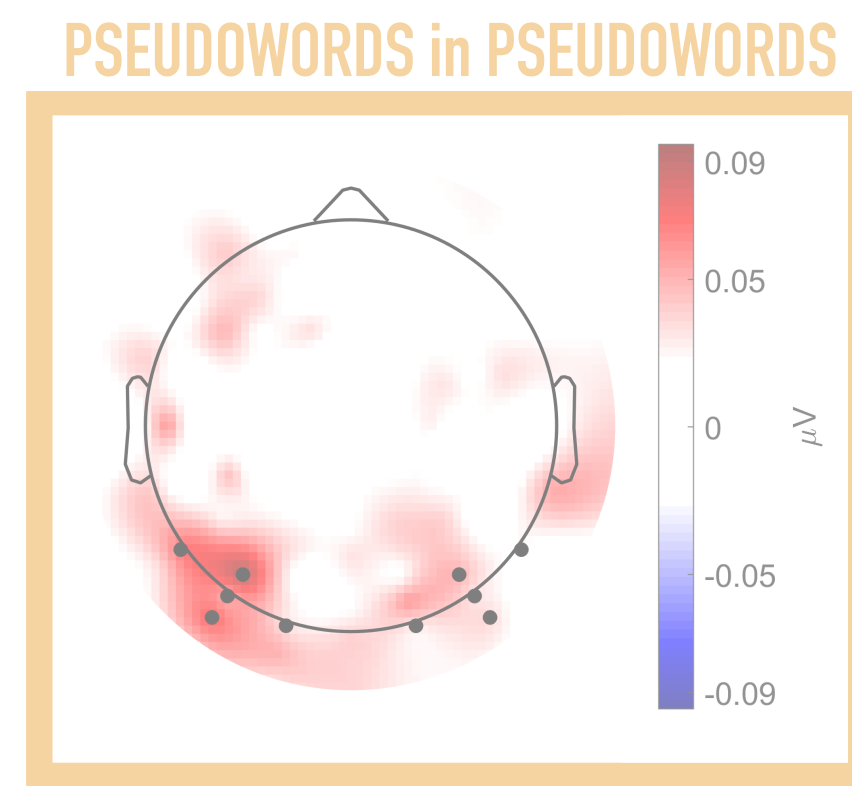
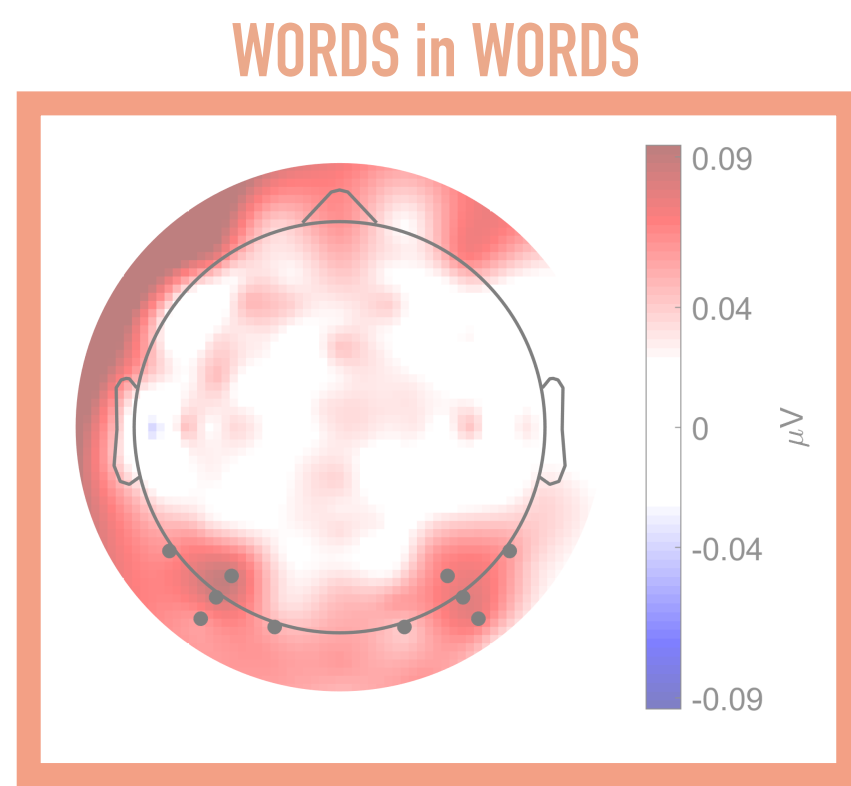

Left ROI

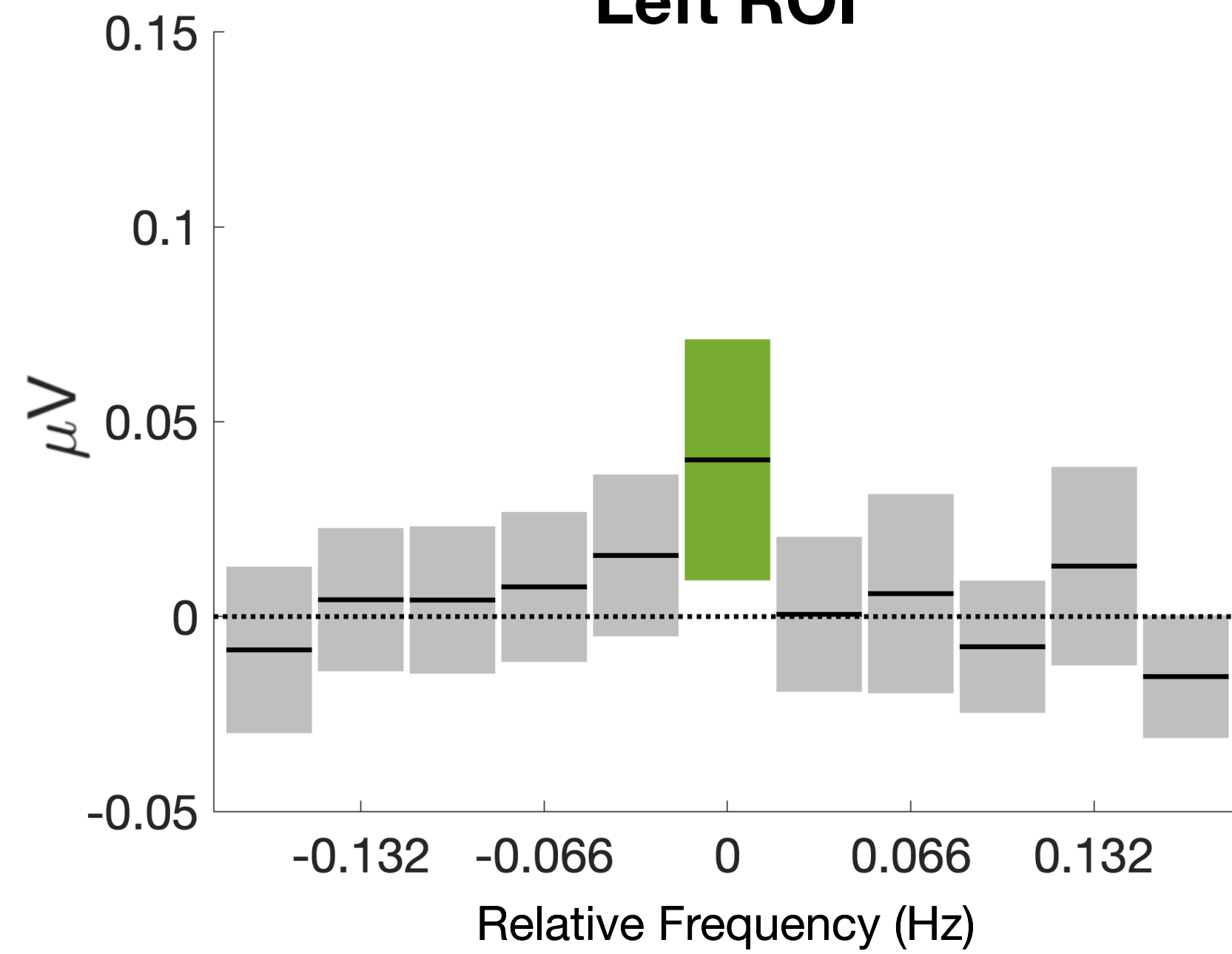

$t = 2.66, g=0.49 [0.10, 0.88] p=0.0127$

Right ROI

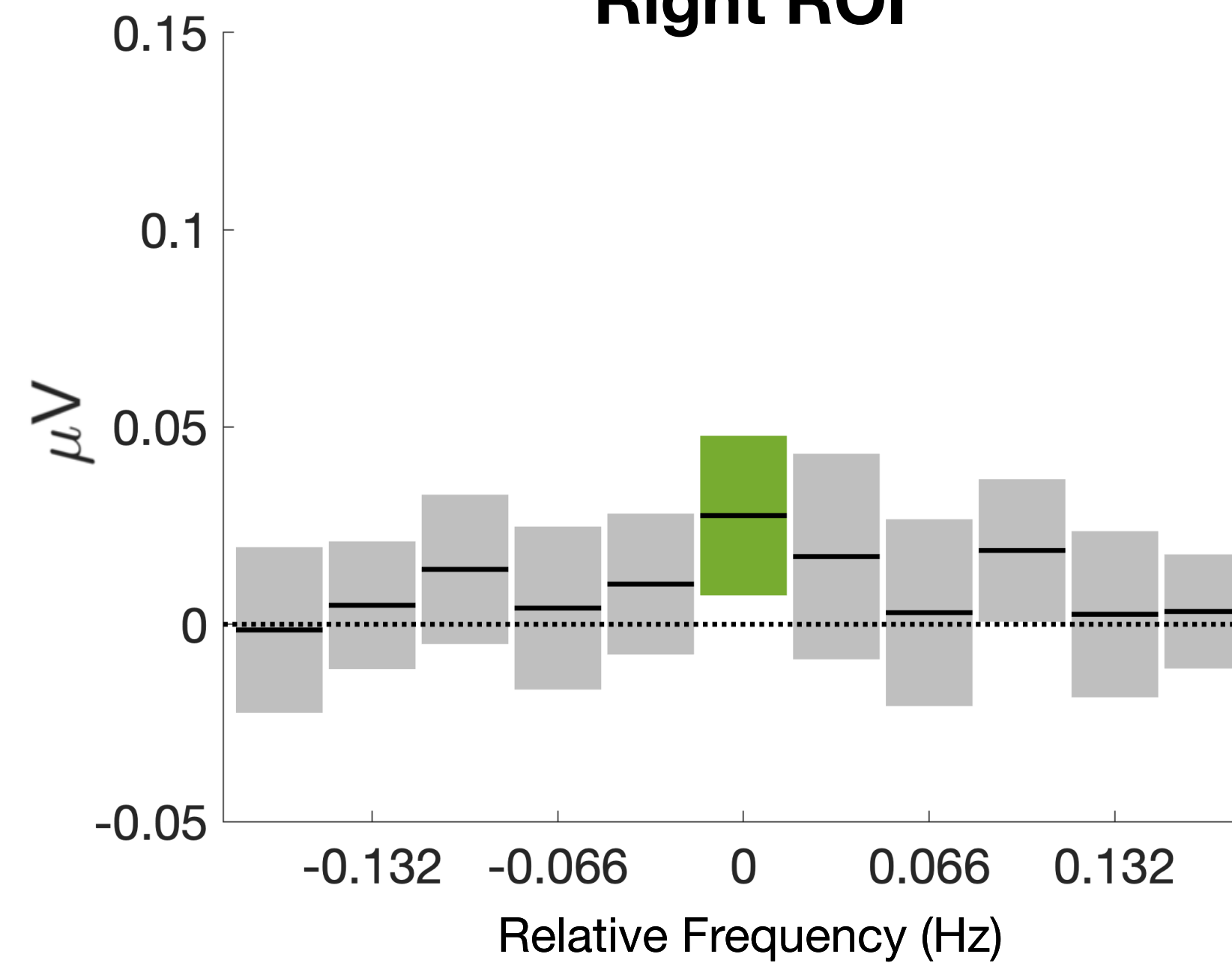

$t = 2.79, g=0.59 [0.13, 0.90] p=0.0093$

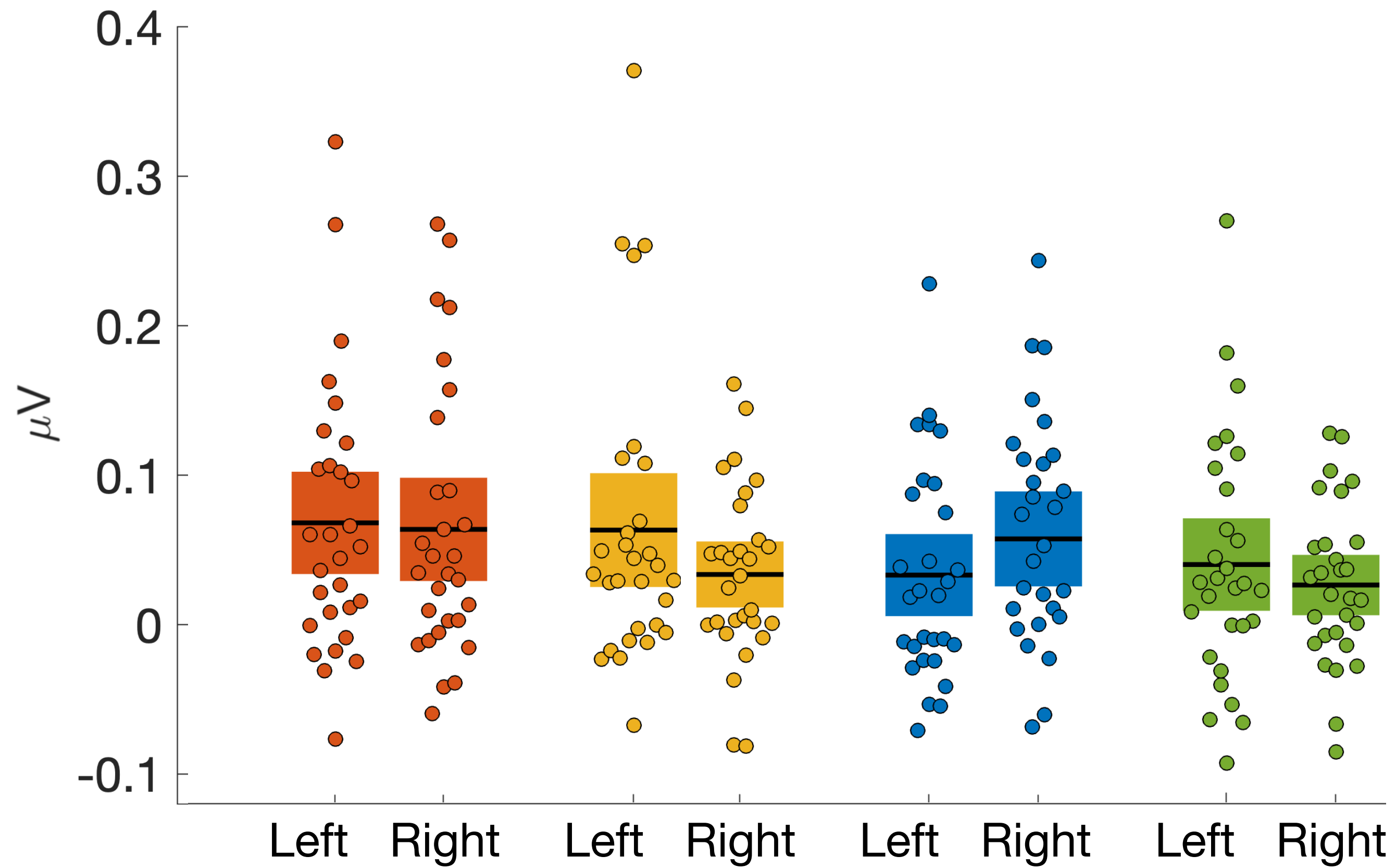
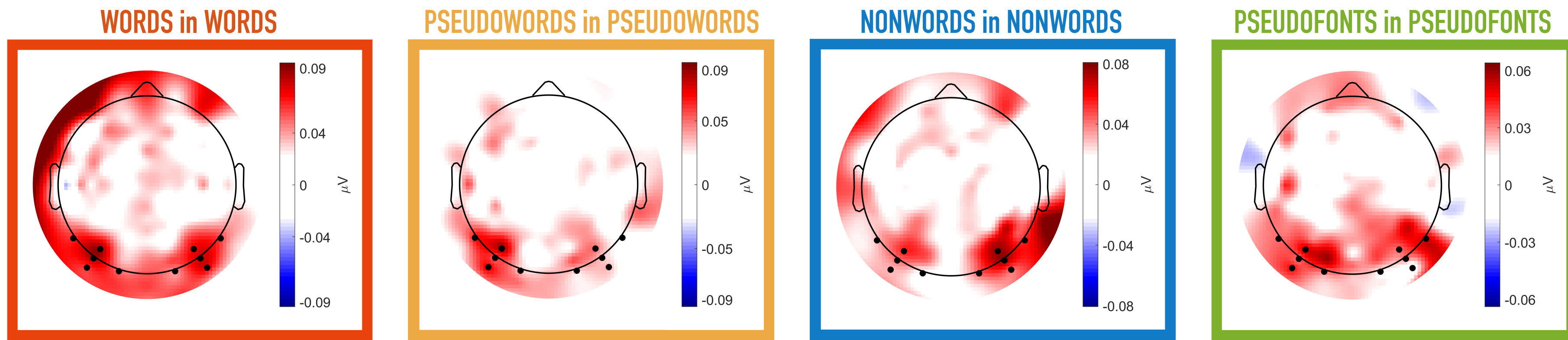

CONDITION:
 $F(3, 84) = 1.243$
 $\eta^2 = 0.022$

HEMISPHERE:
 $F(1, 28) = 0.440$
 $\eta^2 = 0.001$

CONDITION x HEMISPHERE:
 $F(3, 84) = 2.343$
 $\eta^2 = 0.015$

WORDS in WORDS

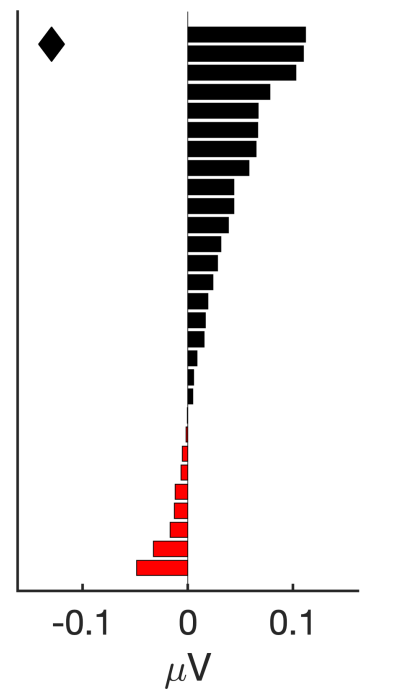
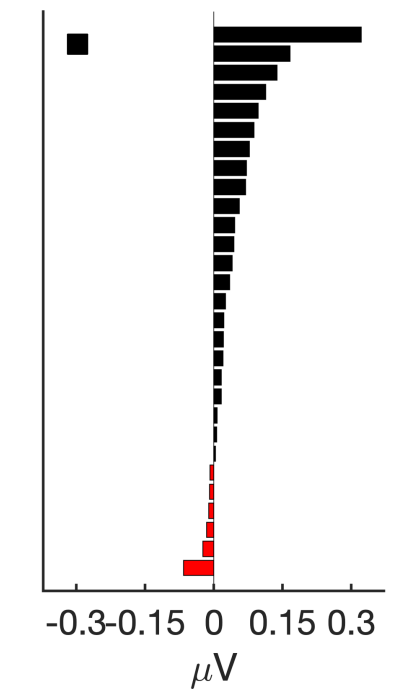
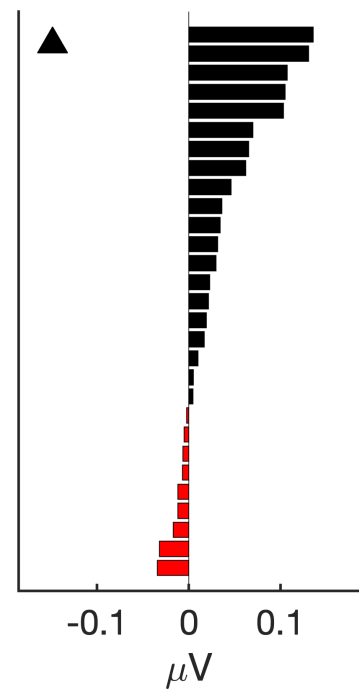
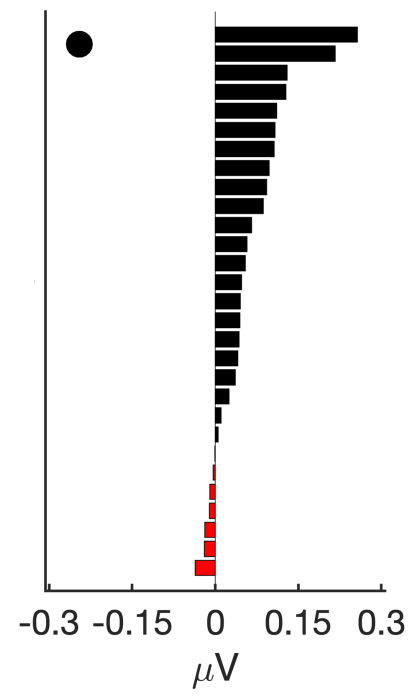
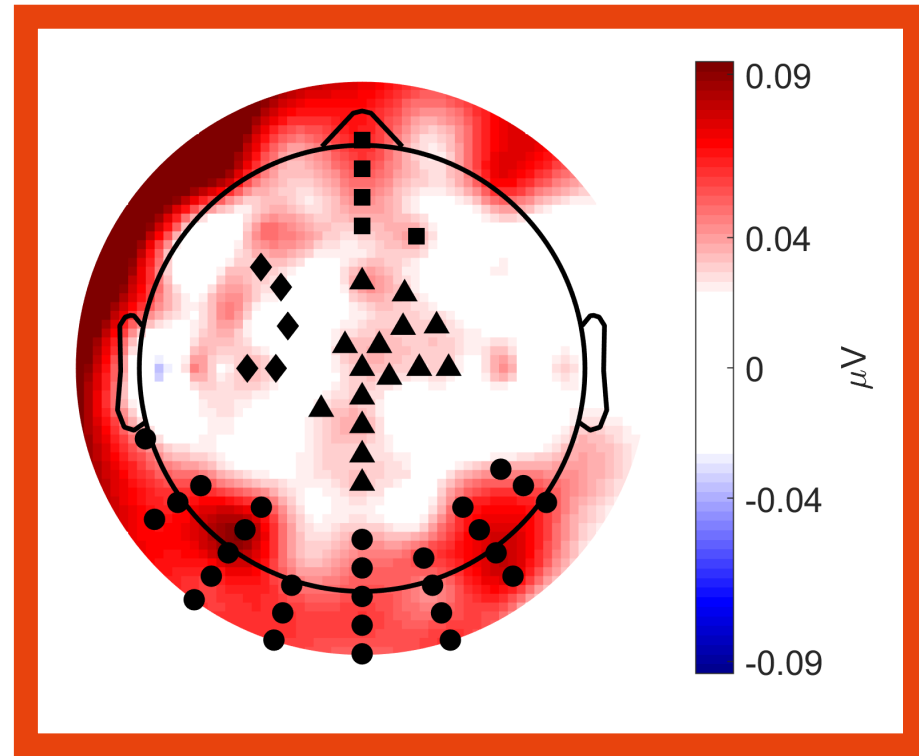

PSEUDOWORDS in PSEUDOWORDS

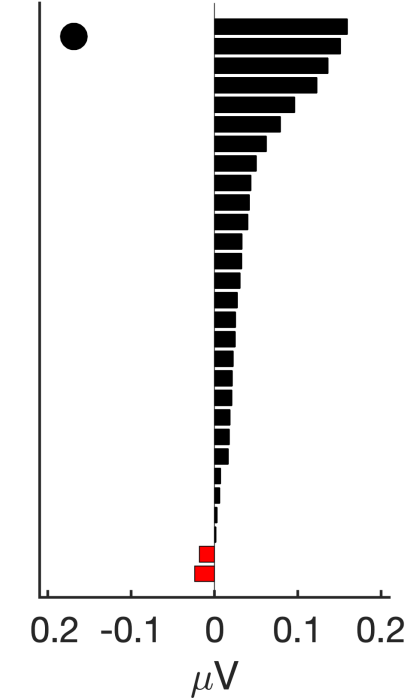
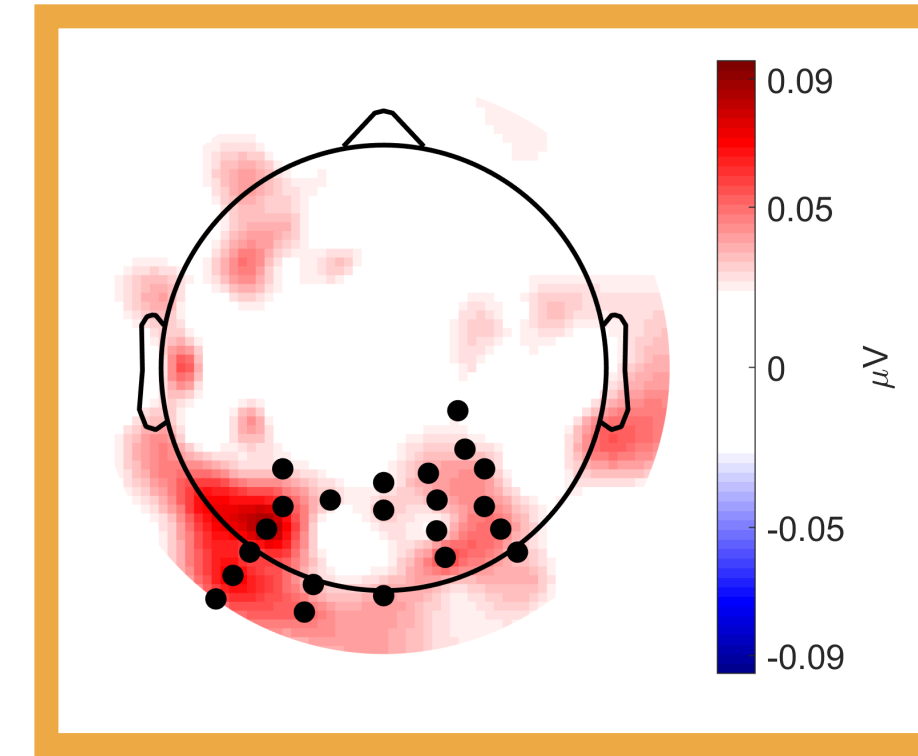

NONWORDS in NONWORDS

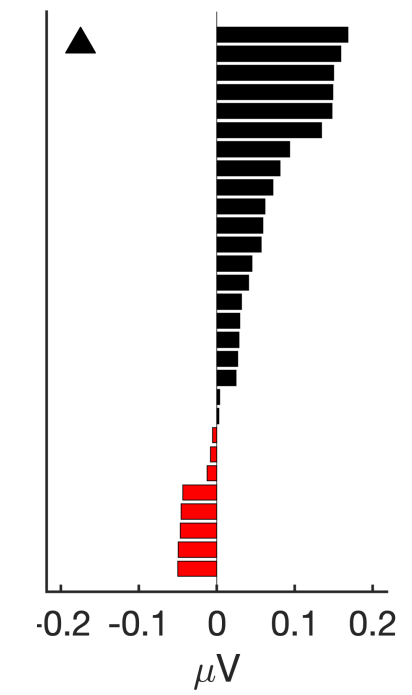
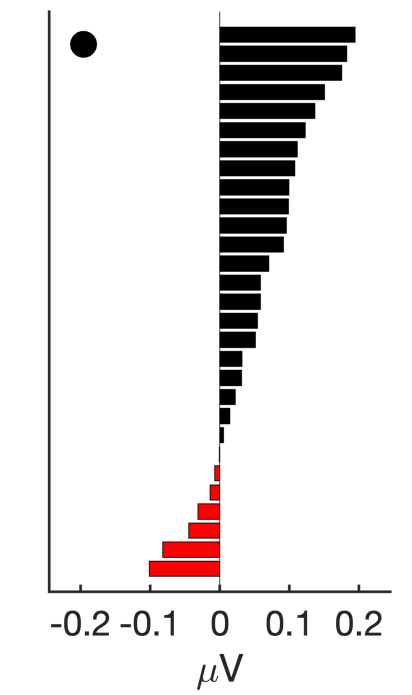
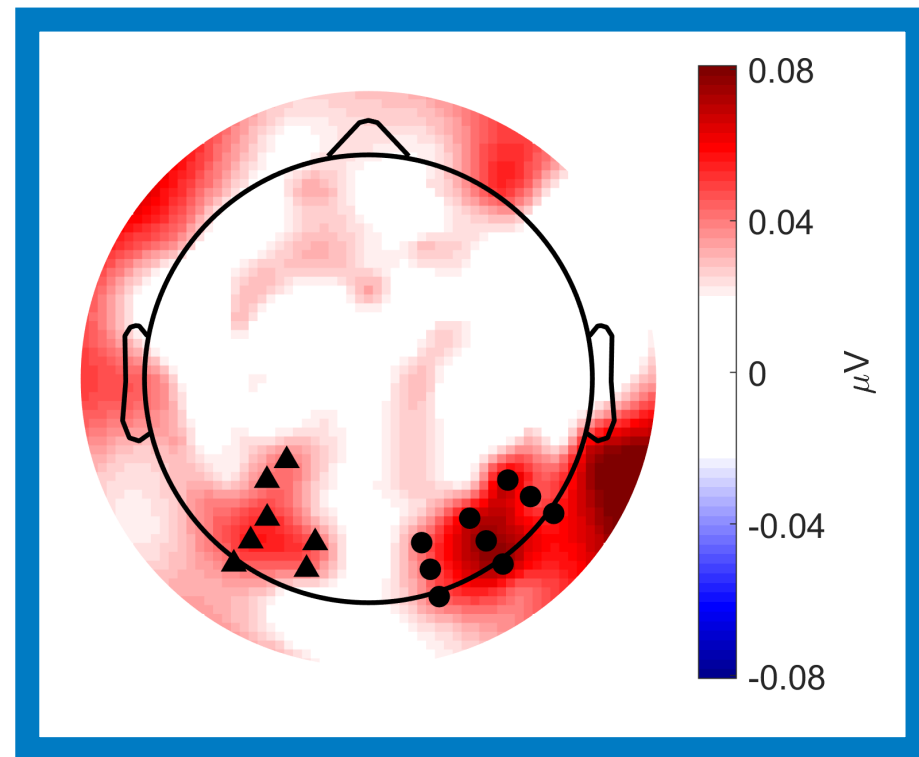

PSEUDOFONTS in PSEUDOFONTS

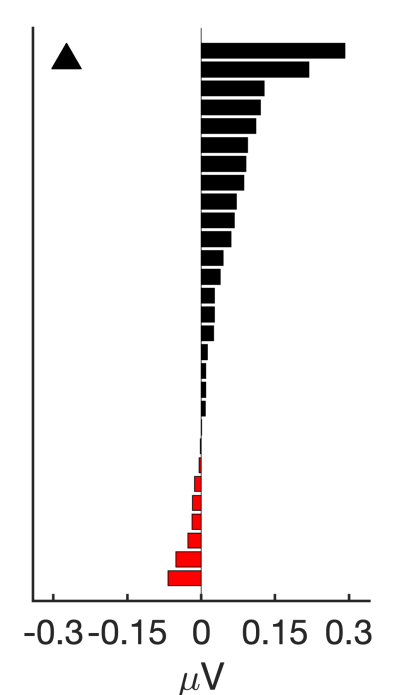
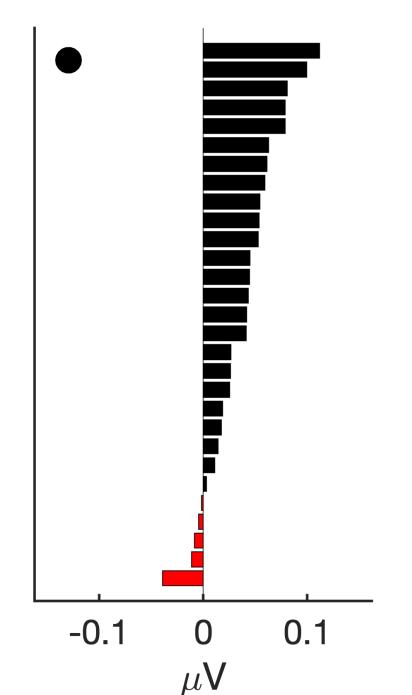
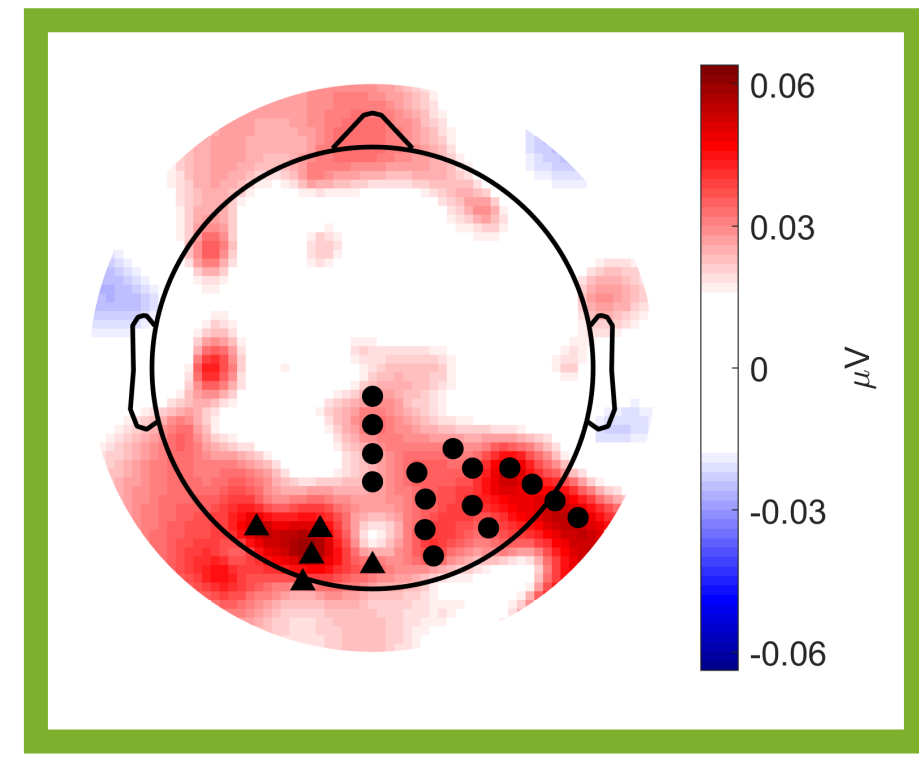

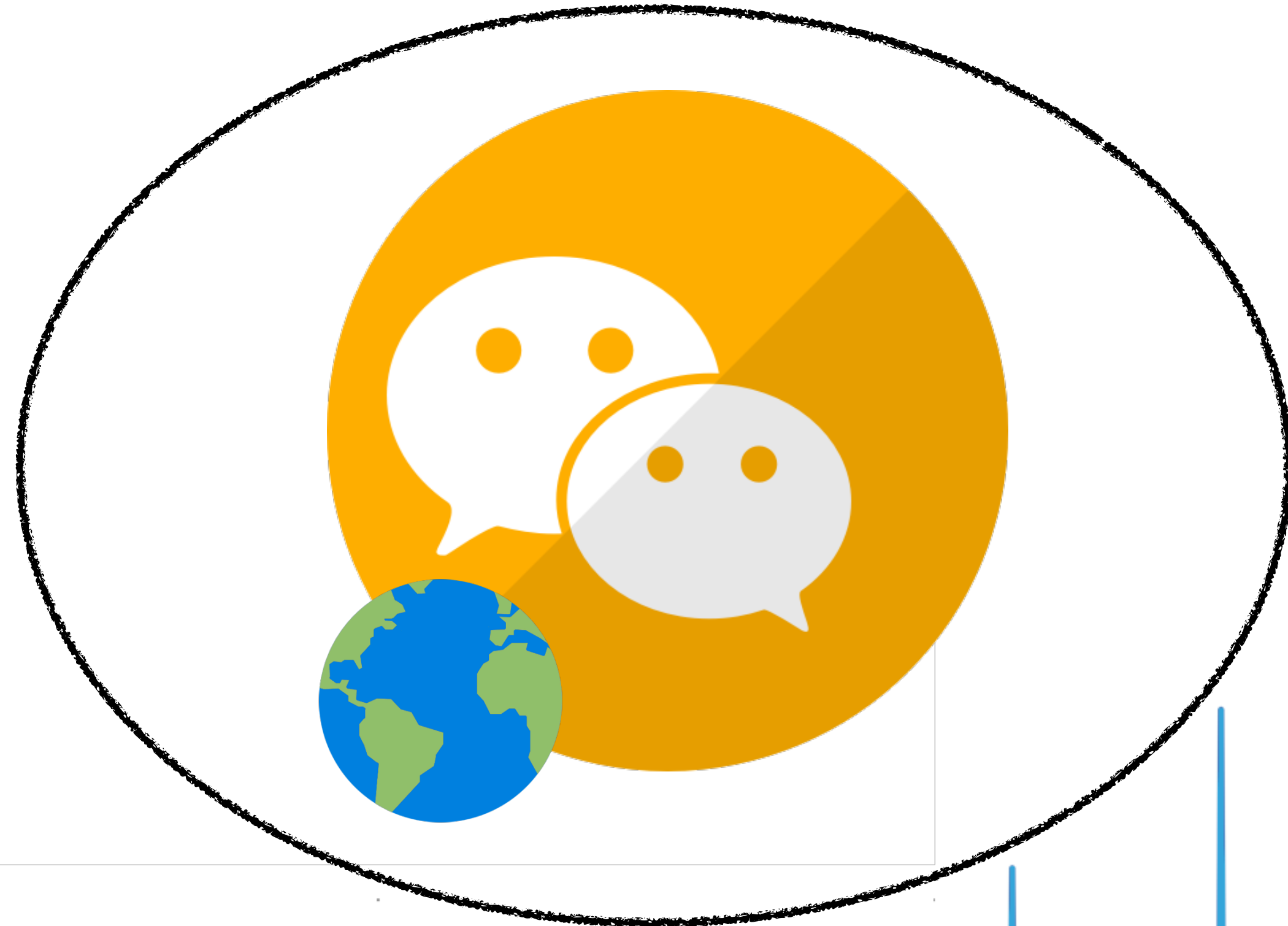
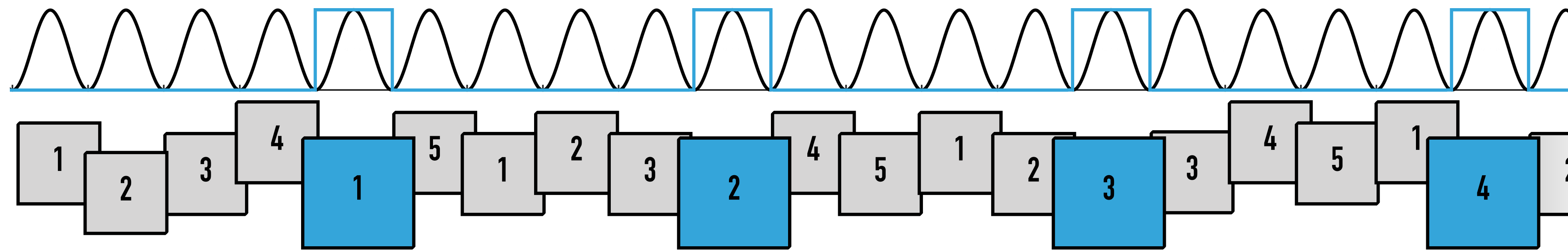

**CATEGORY - SELECTIVE
DISCRIMINATION RESPONSE**

**PURELY BASED ON LOCAL
STATISTICAL REGULARITIES**

**FOR ITEMS BELONGING TO
THE SAME CATEGORY**

**REGARDLESS OF STIMULUS
FAMILIARITY**

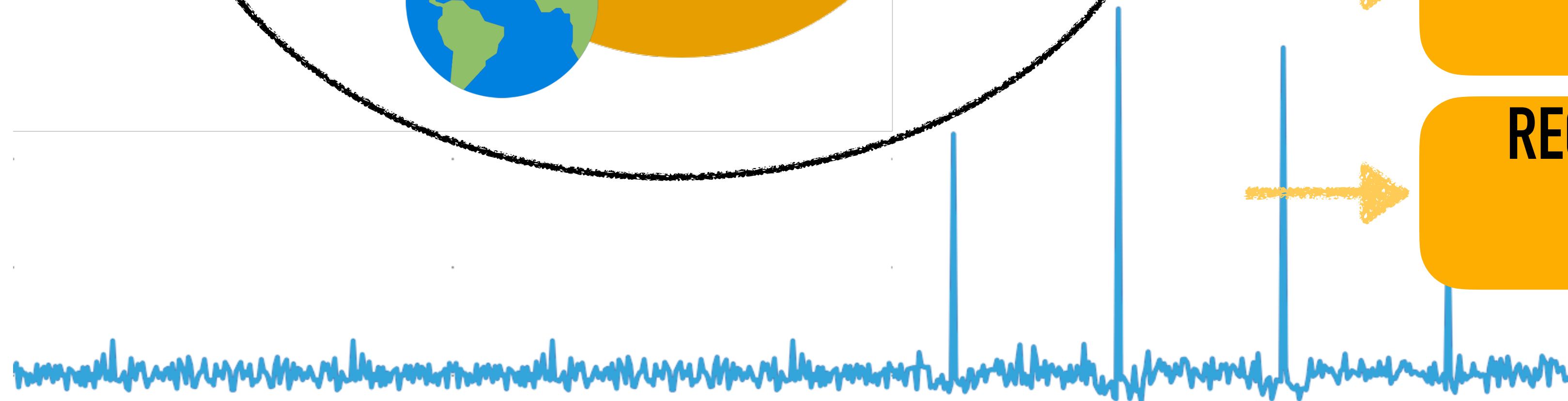

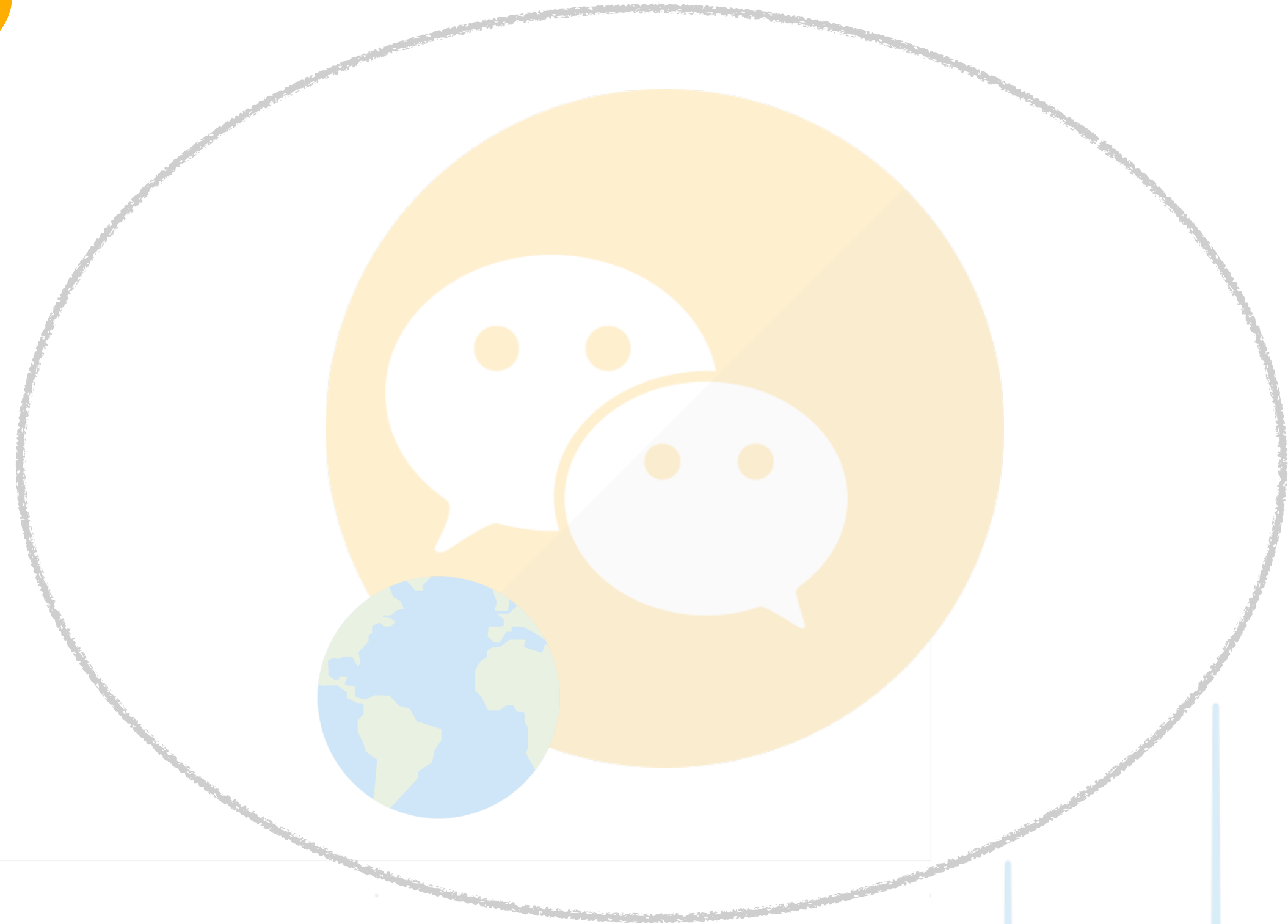
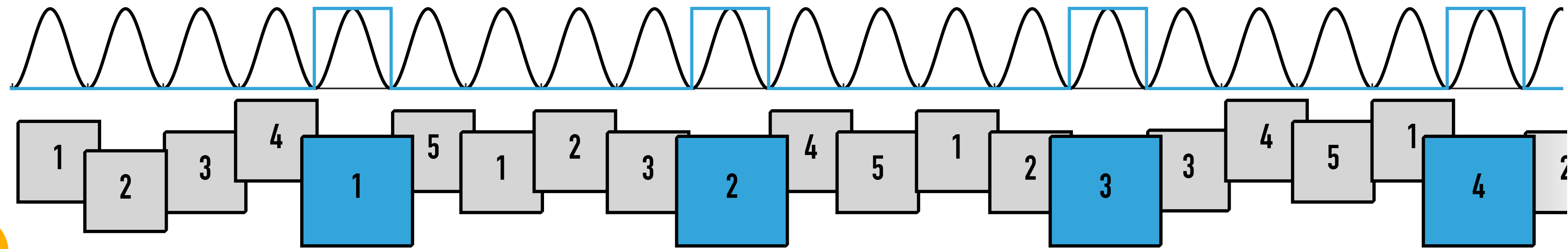

CATEGORY - SELECTIVE
DISCRIMINATION RESPONSE

PURELY BASED ON LOCAL
STATISTICAL REGULARITIES

FOR ITEMS BELONGING TO
THE SAME CATEGORY

REGARDLESS OF STIMULUS
FAMILIARITY



IMPLICIT STATISTICAL LEARNING IN FAST PERIODIC VISUAL STIMULATION

Mara De Rosa¹, Maria Ktori¹, Yamil Vidal¹, Roberto Bottini² & Davide Crepaldi¹

¹International School for Advanced Studies (SISSA), Trieste, Italy

²Center for Mind/Brain Sciences (CIMeC), University of Trento, Trento, Italy



mderosa@sissa.it



European Research Council

Established by the European Commission

REFERENCES

- Ellis, N. C. (2002). Frequency effects in language processing: A review with implications for theories of implicit and explicit language acquisition. *Studies in second language acquisition*, 24(2), 143–188.
- Lochy, A., Van Belle, G., & Rossion, B. (2015). A robust index of lexical representation in the left occipito-temporal cortex as evidenced by EEG responses to fast periodic visual stimulation. *Neuropsychologia*, 66, 18–31.
- Retter, T. L., & Rossion, B. (2016). Uncovering the neural magnitude and spatio-temporal dynamics of natural image categorization in a fast visual stream. *Neuropsychologia*, 91, 9–28.
- Rossion, B. (2014). Understanding face perception by means of human electrophysiology. *Trends in cognitive sciences*, 18(6), 310–318.
- Vidal, C., & Chetail, F. (2017). BACS: The Brussels Artificial Character Sets for studies in cognitive psychology and neuroscience. *Behavior Research Methods*, 49(6), 2093–2112.